

## HAWAII ADMINISTRATIVE RULES

## TITLE 12

## DEPARTMENT OF LABOR AND INDUSTRIAL RELATIONS

## SUBTITLE 8

## DIVISION OF OCCUPATIONAL SAFETY AND HEALTH

## PART 2

## GENERAL INDUSTRY STANDARDS

## CHAPTER 67.2

## GENERAL ENVIRONMENTAL CONTROLS

§12-67.2-1 Field Sanitation  
 §12-67.2-2 Incorporation of federal standard

Historical note: Chapter 12-67.2 is based substantially upon chapter 12-67.1, [Eff 3/29/99; R 12/29/01], chapter 12-68.1, [Eff 3/29/99; R 12/29/01] chapter 12-70, [Eff 12/6/82; am 8/16/84; am 8/15/87; R 12/29/01], 12-101.1 [Eff 9/30/94; am 8/10/95; R 12/29/01], and chapter 12-104. [Eff 7/12/93; am 11/5/93; am 9/30/94; am 7/6/99; R 12/29/01]

**§12-67.2-1 Field sanitation.** (a) This section shall apply to those agricultural establishments where 11 or more employees, other than immediate family members, are employed, on any given day, in hand-labor operations. Toilet facilities in this section shall apply only to migrant agricultural workers. This section shall not apply to agricultural establishments engaged in logging operations, the care or feeding of livestock, or hand-labor operations performed in permanent structures (e.g., canning facilities or packing houses).

(b) Definitions. As used in this section:

"Agricultural employer" means any person, corporation, association, or other legal entity that:

- (1) Owns or operates an agricultural establishment;
- (2) Contracts with the owner or operator of an agricultural establishment in advance of production for the purchase of a crop and exercises substantial control over production; or
- (3) Recruits and supervises employees or is responsible for the management and condition of an agricultural establishment.

"Agricultural establishment" is a business operation that uses paid employees in the production of food, fiber, or other materials such as seeds, seedlings, plants, or parts of plants.

"Hand-labor operations" means agricultural activities or operations performed by hand or with hand tools. Some examples are the hand harvest of vegetables, nuts, fruits, hand weeding of crops, hand planting of seedlings, including mushrooms, and the hand packing of produce into containers, whether done on the ground, on a moving machine, or in a temporary packing shed located in the field.

"Handwashing facility" means a facility providing either a basin, container, or outlet with an adequate supply of potable water, soap, and single-use towels.

"Migrant agricultural worker" means an employee in agricultural employment of a seasonal or temporary nature and who is required to be absent from the employee's permanent place of residence.

"Potable water" means water that meets the standards for drinking purposes by the state or local authority having jurisdiction or water that meets the quality standards prescribed by the United States Environmental Protection

Agency's National Interim Primary, Drinking Water Regulations, published in 40 CFR Part 141.

"Toilet facility" means a fixed or portable facility designed for the purpose of adequate collection and containment of the products of both defecation and urination which is supplied with toilet paper adequate to employee needs. Toilet facility includes biological, chemical, flush and combustion toilets, and sanitary privies.

(c) General requirements.

- (1) Agricultural employers shall provide potable water for all employees engaged in hand-labor operations in the field, without cost to the employee.
- (2) The potable water shall be used exclusively for drinking and handwashing purposes and shall be at locations readily accessible to all employees in the field.
  - (A) The potable water shall be suitably cool and in sufficient amounts, taking into account the air temperature, humidity, and the nature of the work performed, to meet employees' needs.
  - (B) The potable water shall be dispensed in single use drinking cups, individual canteens, other personalized containers. The use of a common drinking cup or dipper is prohibited.
- (3) Toilet and handwashing facilities.
  - (A) One handwashing facility shall be provided for each 20 employees or fraction thereof, except as stated in subparagraph (F) below.
  - (B) Handwashing facilities shall be accessibly located and shall be within a one-quarter mile walk of each hand-laborer's place of work in the field.
  - (C) One toilet facility shall be provided for each 20 migrant agricultural workers or fraction thereof, except as stated in subparagraph (F) below. The facility shall be located within a one-quarter mile walk of each worker in the field.
  - (D) Toilet facilities shall be adequately ventilated, appropriately screened, have self-closing doors that can be closed and latched from the inside, and shall be constructed to ensure privacy.
  - (E) Where due to terrain it is not feasible to locate facilities as required above, the facilities shall be located at the point of closest vehicular access.
  - (F) Toilet and handwashing facilities are not required for employees who perform field work for a period of 3 hours or less (including transportation time to and from the field) during the day.
- (4) Maintenance. Potable drinking water and toilet and handwashing facilities shall be maintained in accordance with appropriate public health sanitation practices, including the following:
  - (A) Drinking water containers shall be constructed of materials that maintain water quality, shall be refilled daily or more often as necessary, shall be kept covered, and shall be regularly cleaned;
  - (B) Toilet facilities shall be operational and maintained in clean and sanitary condition;
  - (C) Handwashing facilities shall be refilled with potable water as necessary to ensure an adequate supply and shall be maintained in a clean and sanitary condition; and
  - (D) Disposal of wastes from facilities shall not cause unsanitary conditions.
- (5) Reasonable use. The employer shall notify each employee of the location of the facilities and shall allow each employee reasonable opportunities during the workday to use the facilities. The employer also shall inform each employee of the importance of each of the following good hygiene practices to minimize exposure to the hazards in the field such as heat, communicable diseases, retention of urine, and agrichemical residues:
  - (A) Use the water and facilities provided for drinking, handwashing, and elimination;
  - (B) Drink water frequently and especially on hot days;
  - (C) Urinate as frequently as necessary;
  - (D) Wash hands before and after using the toilet; and

- (E) Wash hands before eating and smoking.
- (d) Dates.
- (1) Effective date. This section shall take effect 10 days after filing with the office of the lieutenant governor.
  - (2) Startup dates. Employers shall comply with the requirements of the following:
    - (A) Subsection (c)(3), to provide handwashing and toilet facilities, by the sixtieth calendar day after the effective date;
    - (B) Subsection (c)(4), to provide maintenance for toilet and handwashing facilities, by the sixtieth calendar day after the effective date; and
    - (C) Subsection (c)(5), to ensure reasonable use, by the sixtieth calendar day after the effective date. [Eff 12/29/01] (Auth: HRS §396-4) (Imp: HRS §396-4)

**§12-67.2-2 Incorporation of federal standard.** Title 29, Code of Federal Regulations, Subpart J, entitled "General Environmental Controls" published by the Office of the Federal Register, National Archives and Records Administration, on June 27, 1974; and the amendments published on April 28, 1975; May 28, 1975; October 24, 1978; November 7, 1978; April 26, 1982; February 10, 1984; April 30, 1984; September 19, 1986; September 1, 1989; October 17, 1989; September 20, 1990; January 14, 1993; June 29, 1993; May 19, 1994; March 7, 1996; June 18, 1998; December 1, 1998; January 5, 2005; and September 13, 2005, are made part of this chapter, except as provided in section 12-67.2-1. [Eff 12/29/01; am 3/31/06] (Auth: HRS §396-4) (Imp: HRS §396-4)

### **§1910.141 Sanitation.**

- (a) General.
- (1) Scope. This section applies to permanent places of employment.
  - (2) Definitions applicable to this section.
 

**Nonwater carriage toilet facility**, means a toilet facility not connected to a sewer.

**Number of employees** means, unless otherwise specified, the maximum number of employees present at any one time on a regular shift.

**Personal service room**, means a room used for activities not directly connected with the production or service function performed by the establishment. Such activities include, but are not limited to, first-aid, medical services, dressing, showering, toilet use, washing, and eating.

**Potable water** means water which meets the quality standards prescribed in the U.S. Public Health Service Drinking Water Standards, published in 42 CFR part 72, or water which is approved for drinking purposes by the State or local authority having jurisdiction.

**Toilet facility**, means a fixture maintained within a toilet room for the purpose of defecation or urination, or both.

**Toilet room**, means a room maintained within or on the premises of any place of employment, containing toilet facilities for use by employees.

**Toxic material** means a material in concentration or amount which exceeds the applicable limit established by a standard, such as §§1910.1000 and 1910.1001 or, in the absence of an applicable standard, which is of such toxicity so as to constitute a recognized hazard that is causing or is likely to cause death or serious physical harm.

**Urinal** means a toilet facility maintained within a toilet room for the sole purpose of urination.

**Water closet** means a toilet facility maintained within a toilet room for the purpose of both defecation and urination and which is flushed with water.

**Wet process** means any process or operation in a workroom which normally results in surfaces upon which employees may walk or stand becoming wet.
  - (3) Housekeeping.
    - (i) All places of employment shall be kept clean to the extent that the nature of the work allows.
    - (ii) The floor of every workroom shall be maintained, so far as practicable, in a dry condition. Where wet processes are used, drainage shall be maintained and false floors, platforms,

mats, or other dry standing places shall be provided, where practicable, or appropriate waterproof footwear shall be provided.

- (iii) To facilitate cleaning, every floor, working place, and passageway shall be kept free from protruding nails, splinters, loose boards, and unnecessary holes and openings.
- (4) Waste disposal.
  - (i) Any receptacle used for putrescible solid or liquid waste or refuse shall be so constructed that it does not leak and may be thoroughly cleaned and maintained in a sanitary condition. Such a receptacle shall be equipped with a solid tight-fitting cover, unless it can be maintained in a sanitary condition without a cover. This requirement does not prohibit the use of receptacles which are designed to permit the maintenance of a sanitary condition without regard to the aforementioned requirements.
  - (ii) All sweepings, solid or liquid wastes, refuse, and garbage shall be removed in such a manner as to avoid creating a menace to health and as often as necessary or appropriate to maintain the place of employment in a sanitary condition.
- (5) Vermin control. Every enclosed workplace shall be so constructed, equipped, and maintained, so far as reasonably practicable, as to prevent the entrance or harborage of rodents, insects, and other vermin. A continuing and effective extermination program shall be instituted where their presence is detected.
- (b) Water supply.**
  - (1) Potable water.
    - (i) Potable water shall be provided in all places of employment, for drinking, washing of the person, cooking, washing of foods, washing of cooking or eating utensils, washing of food preparation or processing premises, and personal service rooms.
    - (ii) [Reserved]
    - (iii) Portable drinking water dispensers shall be designed, constructed, and serviced so that sanitary conditions are maintained, shall be capable of being closed, and shall be equipped with a tap.
    - (iv) [Reserved]
    - (v) Open containers such as barrels, pails, or tanks for drinking water from which the water must be dipped or poured, whether or not they are fitted with a cover, are prohibited.
    - (vi) A common drinking cup and other common utensils are prohibited.
  - (2) Nonpotable water.
    - (i) Outlets for nonpotable water, such as water for industrial or firefighting purposes, shall be posted or otherwise marked in a manner that will indicate clearly that the water is unsafe and is not to be used for drinking, washing of the person, cooking, washing of food, washing of cooking or eating utensils, washing of food preparation or processing premises, or personal service rooms, or for washing clothes.
    - (ii) Construction of nonpotable water systems or systems carrying any other nonpotable substance shall be such as to prevent backflow or backsiphonage into a potable water system.
    - (iii) Nonpotable water shall not be used for washing any portion of the person, cooking or eating utensils, or clothing. Nonpotable water may be used for cleaning work premises, other than food processing and preparation premises and personal service rooms: Provided, That this nonpotable water does not contain concentrations of chemicals, fecal coliform, or other substances which could create insanitary conditions or be harmful to employees.
- (c) Toilet facilities.**
  - (1) General.
    - (i) Except as otherwise indicated in this paragraph (c)(1)(i), toilet facilities, in toilet rooms separate for each sex, shall be provided in all places of employment in accordance with table J-1 of this section. The number of facilities to be provided for each sex shall be based on the number of employees of that sex for whom the facilities are furnished. Where toilet rooms will be occupied by no more than one person at a time, can be locked from the inside, and contain at least one water closet, separate toilet rooms for each sex need not be provided. Where such single-occupancy rooms have more than one toilet facility, only one such facility in each toilet room shall be counted for the purpose of table J-1.

TABLE J-1

Number of employees	Minimum number of water closets <sup>1</sup>
1 to 15 .....	1
16 to 35 .....	2
36 to 55 .....	3
56 to 80 .....	4
81 to 110 .....	5
111 to 150 .....	6
Over 150.....	( <sup>2</sup> )

<sup>1</sup>Where toilet facilities will not be used by women, urinals may be provided instead of water closets, except that the number of water closets in such cases shall not be reduced to less than 2/3 of the minimum specified.

<sup>2</sup>1 additional fixture for each additional 40 employees.

- (ii) The requirements of paragraph (c)(1)(i) of this section do not apply to mobile crews or to normally unattended work locations so long as employees working at these locations have transportation immediately available to nearby toilet facilities which meet the other requirements of this subparagraph.
- (iii) The sewage disposal method shall not endanger the health of employees.
- (2) Construction of toilet rooms.
  - (i) Each water closet shall occupy a separate compartment with a door and walls or partitions between fixtures sufficiently high to assure privacy.
  - (ii) [Reserved]
- (d) Washing facilities.**
  - (1) General. Washing facilities shall be maintained in a sanitary condition.
  - (2) Lavatories.
    - (i) Lavatories shall be made available in all places of employment. The requirements of this subdivision do not apply to mobile crews or to normally unattended work locations if employees working at these locations have transportation readily available to nearby washing facilities which meet the other requirements of this paragraph.
    - (ii) Each lavatory shall be provided with hot and cold running water, or tepid running water.
    - (iii) Hand soap or similar cleansing agents shall be provided.
    - (iv) Individual hand towels or sections thereof, of cloth or paper, warm air blowers or clean individual sections of continuous cloth toweling, convenient to the lavatories, shall be provided.
  - (3) Showers.
    - (i) Whenever showers are required by a particular standard, the showers shall be provided in accordance with paragraphs (d)(3)(ii) through (v) of this section.
    - (ii) One shower shall be provided for each 10 employees of each sex, or numerical fraction thereof, who are required to shower during the same shift.
    - (iii) Body soap or other appropriate cleansing agents convenient to the showers shall be provided as specified in paragraph (d)(2)(iii) of this section.
    - (iv) Showers shall be provided with hot and cold water feeding a common discharge line.
    - (v) Employees who use showers shall be provided with individual clean towels.
- (e) Change rooms.** Whenever employees are required by a particular standard to wear protective clothing because of the possibility of contamination with toxic materials, change rooms equipped with storage facilities for street clothes and separate storage facilities for the protective clothing shall be provided.
- (f) Clothes drying facilities.** Where working clothes are provided by the employer and become wet or are washed between shifts, provision shall be made to insure that such clothing is dry before reuse.
- (g) Consumption of food and beverages on the premises.**
  - (1) Application. This paragraph shall apply only where employees are permitted to consume food or beverages, or both, on the premises.

- (2) Eating and drinking areas. No employee shall be allowed to consume food or beverages in a toilet room nor in any area exposed to a toxic material.
  - (3) Waste disposal containers. Receptacles constructed of smooth, corrosion resistant, easily cleanable, or disposable materials, shall be provided and used for the disposal of waste food. The number, size, and location of such receptacles shall encourage their use and not result in overfilling. They shall be emptied not less frequently than once each working day, unless unused, and shall be maintained in a clean and sanitary condition. Receptacles shall be provided with a solid tight-fitting cover unless sanitary conditions can be maintained without use of a cover.
  - (4) Sanitary storage. No food or beverages shall be stored in toilet rooms or in an area exposed to a toxic material.
- (h) Food handling. All employee food service facilities and operations shall be carried out in accordance with sound hygienic principles. In all places of employment where all or part of the food service is provided, the food dispensed shall be wholesome, free from spoilage, and shall be processed, prepared, handled, and stored in such a manner as to be protected against contamination.

**§1910.142 Temporary Labor Camps.**

**(a) Site.**

- (1) All sites used for camps shall be adequately drained. They shall not be subject to periodic flooding, nor located within 200 feet of swamps, pools, sink holes, or other surface collections of water unless such quiescent water surfaces can be subjected to mosquito control measures. The camp shall be located so the drainage from and through the camp will not endanger any domestic or public water supply. All sites shall be graded, ditched, and rendered free from depressions in which water may become a nuisance.
- (2) All sites shall be adequate in size to prevent overcrowding of necessary structures. The principal camp area in which food is prepared and served and where sleeping quarters are located shall be at least 500 feet from any area in which livestock is kept.
- (3) The grounds and open areas surrounding the shelters shall be maintained in a clean and sanitary condition free from rubbish, debris, waste paper, garbage, or other refuse.

**(b) Shelter.**

- (1) Every shelter in the camp shall be constructed in a manner which will provide protection against the elements.
- (2) Each room used for sleeping purposes shall contain at least 50 square feet of floor space for each occupant. At least a 7-foot ceiling shall be provided.
- (3) Beds, cots, or bunks, and suitable storage facilities such as wall lockers for clothing and personal articles shall be provided in every room used for sleeping purposes. Such beds or similar facilities shall be spaced not closer than 36 inches both laterally and end to end, and shall be elevated at least 12 inches from the floor. If double-deck bunks are used, they shall be spaced not less than 48 inches both laterally and end to end. The minimum clear space between the lower and upper bunk shall be not less than 27 inches. Triple-deck bunks are prohibited.
- (4) The floors of each shelter shall be constructed of wood, asphalt, or concrete. Wooden floors shall be of smooth and tight construction. The floors shall be kept in good repair.
- (5) All wooden floors shall be elevated not less than 1 foot above the ground level at all points to prevent dampness and to permit free circulation of air beneath.
- (6) Nothing in this section shall be construed to prohibit "banking" with earth or other suitable material around the outside walls in areas subject to extreme low temperatures.
- (7) All living quarters shall be provided with windows the total of which shall be not less than one-tenth of the floor area. At least one-half of each window shall be so constructed that it can be opened for purposes of ventilation.
- (8) All exterior openings shall be effectively screened with 16-mesh material. All screen doors shall be equipped with self-closing devices.
- (9) In a room where workers cook, live, and sleep a minimum of 100 square feet per person shall be provided. Sanitary facilities shall be provided for storing and preparing food.
- (10) In camps where cooking facilities are used in common, stoves (in ratio of one stove to 10 persons or one stove to two families) shall be provided in an enclosed and screened shelter.

Sanitary facilities shall be provided for storing and preparing food.

- (11) All heating, cooking, and water heating equipment shall be installed in accordance with State and local ordinances, codes, and regulations governing such installations. If a camp is used during cold weather, adequate heating equipment shall be provided.
- (c) Water supply.**
- (1) An adequate and convenient water supply, approved by the appropriate health authority, shall be provided in each camp for drinking, cooking, bathing, and laundry purposes.
  - (2) A water supply shall be deemed adequate if it is capable of delivering 35 gallons per person per day to the campsite at a peak rate of 2 1/2 times the average hourly demand.
  - (3) The distribution lines shall be capable of supplying water at normal operating pressures to all fixtures for simultaneous operation. Water outlets shall be distributed throughout the camp in such a manner that no shelter is more than 100 feet from a yard hydrant if water is not piped to the shelters.
  - (4) Where water under pressure is available, one or more drinking fountains shall be provided for each 100 occupants or fraction thereof. The construction of drinking fountains shall comply with ANSI Standard Specifications for Drinking Fountains, Z4.2-1942, which is incorporated by reference as specified in §1910.6. Common drinking cups are prohibited.
- (d) Toilet facilities.**
- (1) Toilet facilities adequate for the capacity of the camp shall be provided.
  - (2) Each toilet room shall be located so as to be accessible without any individual passing through any sleeping room. Toilet rooms shall have a window not less than 6 square feet in area opening directly to the outside area or otherwise be satisfactorily ventilated. All outside openings shall be screened with 16-mesh material. No fixture, water closet, chemical toilet, or urinal shall be located in a room used for other than toilet purposes.
  - (3) A toilet room shall be located within 200 feet of the door of each sleeping room. No privy shall be closer than 100 feet to any sleeping room, dining room, lunch area, or kitchen.
  - (4) Where the toilet rooms are shared, such as in multifamily shelters and in barracks type facilities, separate toilet rooms shall be provided for each sex. These rooms shall be distinctly marked "for men" and "for women" by signs printed in English and in the native language of the persons occupying the camp, or marked with easily understood pictures or symbols. If the facilities for each sex are in the same building, they shall be separated by solid walls or partitions extending from the floor to the roof or ceiling.
  - (5) Where toilet facilities are shared, the number of water closets or privy seats provided for each sex shall be based on the maximum number of persons of that sex which the camp is designed to house at any one time, in the ratio of one such unit to each 15 persons, with a minimum of two units for any shared facility.
  - (6) Urinals shall be provided on the basis of one unit or 2 linear feet of urinal trough for each 25 men. The floor from the wall and for a distance not less than 15 inches measured from the outward edge of the urinals shall be constructed of materials impervious to moisture. Where water under pressure is available, urinals shall be provided with an adequate water flush. Urinal troughs in privies shall drain freely into the pit or vault and the construction of this drain shall be such as to exclude flies and rodents from the pit.
  - (7) Every water closet installed on or after August 31, 1971, shall be located in a toilet room.
  - (8) Each toilet room shall be lighted naturally, or artificially by a safe type of lighting at all hours of the day and night.
  - (9) An adequate supply of toilet paper shall be provided in each privy, water closet, or chemical toilet compartment.
  - (10) Privies and toilet rooms shall be kept in a sanitary condition. They shall be cleaned at least daily.
- (e) Sewage disposal facilities.** In camps where public sewers are available, all sewer lines and floor drains from buildings shall be connected thereto.
- (f) Laundry, handwashing, and bathing facilities.**
- (1) Laundry, handwashing, and bathing facilities shall be provided in the following ratio:
    - (i) Handwash basin per family shelter or per six persons in shared facilities.
    - (ii) Shower head for every 10 persons.
    - (iii) Laundry tray or tub for every 30 persons.

- (iv) Slop sink in each building used for laundry, hand washing, and bathing.
- (2) Floors shall be of smooth finish but not slippery materials; they shall be impervious to moisture. Floor drains shall be provided in all shower baths, shower rooms, or laundry rooms to remove waste water and facilitate cleaning. All junctions of the curbing and the floor shall be coved. The walls and partitions of shower rooms shall be smooth and impervious to the height of splash.
- (3) An adequate supply of hot and cold running water shall be provided for bathing and laundry purposes. Facilities for heating water shall be provided.
- (4) Every service building shall be provided with equipment capable of maintaining a temperature of at least 70° F. during cold weather.
- (5) Facilities for drying clothes shall be provided.
- (6) All service buildings shall be kept clean.
- (g) Lighting. Where electric service is available, each habitable room in a camp shall be provided with at least one ceiling-type light fixture and at least one separate floor- or wall-type convenience outlet. Laundry and toilet rooms and rooms where people congregate shall contain at least one ceiling- or wall-type fixture. Light levels in toilet and storage rooms shall be at least 20 foot-candles 30 inches from the floor. Other rooms, including kitchens and living quarters, shall be at least 30 foot-candles 30 inches from the floor.
- (h) Refuse disposal.
  - (1) Fly-tight, rodent-tight, impervious, cleanable or single service containers, approved by the appropriate health authority shall be provided for the storage of garbage. At least one such container shall be provided for each family shelter and shall be located within 100 feet of each shelter on a wooden, metal, or concrete stand.
  - (2) Garbage containers shall be kept clean.
  - (3) Garbage containers shall be emptied when full, but not less than twice a week.
- (i) Construction and operation of kitchens, dining hall, and feeding facilities.
  - (1) In all camps where central dining or multiple family feeding operations are permitted or provided, the food handling facilities shall comply with the requirements of the "Food Service Sanitation Ordinance and Code," Part V of the "Food Service Sanitation Manual," U.S. Public Health Service Publication 934 (1965), which is incorporated by reference as specified in §1910.6.
  - (2) A properly constructed kitchen and dining hall adequate in size, separate from the sleeping quarters of any of the workers or their families, shall be provided in connection with all food handling facilities. There shall be no direct opening from living or sleeping quarters into a kitchen or dining hall.
  - (3) No person with any communicable disease shall be employed or permitted to work in the preparation, cooking, serving, or other handling of food, foodstuffs, or materials used therein, in any kitchen or dining room operated in connection with a camp or regularly used by persons living in a camp.
- (j) Insect and rodent control. Effective measures shall be taken to prevent infestation by and harborage of animal or insect vectors or pests.
- (k) First aid.
  - (1) Adequate first aid facilities approved by a health authority shall be maintained and made available in every labor camp for the emergency treatment of injured persons.
  - (2) Such facilities shall be in charge of a person trained to administer first aid and shall be readily accessible for use at all times.
- (l) Reporting communicable disease.
  - (1) It shall be the duty of the camp superintendent to report immediately to the local health officer the name and address of any individual in the camp known to have or suspected of having a communicable disease.
  - (2) Whenever there shall occur in any camp a case of suspected food poisoning or an unusual prevalence of any illness in which fever, diarrhea, sore throat, vomiting, or jaundice is a prominent symptom, it shall be the duty of the camp superintendent to report immediately the existence of the outbreak to the health authority by telegram, telephone, electronic mail or any method that is equally fast.

**§1910.143 Nonwater carriage disposal systems. [Reserved]**



**§1910.144 Safety color code for marking physical hazards.**

- (a) Color identification.
- (1) Red. Red shall be the basic color for the identification of:
    - (i) Fire protection equipment and apparatus. [Reserved]
    - (ii) Danger. Safety cans or other portable containers of flammable liquids having a flash point at or below 80 EF, table containers of flammable liquids (open cup tester), excluding shipping containers, shall be painted red with some additional clearly visible identification either in the form of a yellow band around the can or the name of the contents conspicuously stenciled or painted on the can in yellow. Red lights shall be provided at barricades and at temporary obstructions, as specified in ANSI Safety Code for Building Construction, A10.2-1944, which is incorporated by reference as specified in §1910.6. Danger signs shall be painted red.
    - (iii) Stop. Emergency stop bars on hazardous machines such as rubber mills, wire blocks, flat work ironers, etc., shall be red. Stop buttons or electrical switches which letters or other markings appear, used for emergency stopping of machinery shall be red.
  - (2) [Reserved]
  - (3) Yellow. Yellow shall be the basic color for designating caution and for marking physical hazards such as: Striking against, stumbling, falling, tripping, and "caught in between."

**§1910.145 Specifications for accident prevention signs and tags.**

- (a) Scope.
- (1) These specifications apply to the design, application, and use of signs or symbols (as included in paragraphs (c) through (e) of this section) intended to indicate and, insofar as possible, to define specific hazards of a nature such that failure to designate them may lead to accidental injury to workers or the public, or both, or to property damage. These specifications are intended to cover all safety signs except those designed for streets, highways, railroads, and marine regulations. These specifications do not apply to plant bulletin boards or to safety posters.
  - (2) All new signs and replacements of old signs shall be in accordance with these specifications.
- (b) Definitions. As used in this section, the word **sign** refers to a surface on prepared for the warning of, or safety instructions of, industrial workers or members of the public who may be exposed to hazards. Excluded from this definition, however, are news releases, displays commonly known as safety posters, and bulletins used for employee education.
- (c) Classification of signs according to use.
- (1) Danger signs.
    - (i) There shall be no variation in the type of design of signs posted to warn of specific dangers and radiation hazards.
    - (ii) All employees shall be instructed that danger signs indicate immediate danger and that special precautions are necessary.
  - (2) Caution signs.
    - (i) Caution signs shall be used only to warn against potential hazards or to caution against unsafe practices.
    - (ii) All employees shall be instructed that caution signs indicate a possible hazard against which proper precaution should be taken.
  - (3) Safety instruction signs. Safety instruction signs shall be used where there is a need for general instructions and suggestions relative to safety measures.
- (d) Sign design.
- (1) Design features. All signs shall be furnished with rounded or blunt corners and shall be free from sharp edges, burrs, splinters, or other sharp projections. The ends or heads of bolts or other fastening devices shall be located in such a way that they do not constitute a hazard.
  - (2) Danger signs. The colors red, black, and white shall be those of opaque glossy samples as specified in Table 1 of Fundamental Specification of Safety Colors for CIE Standard Source "C", American National Standard Z53.1-1967, which is incorporated by reference as specified in §1910.6.
  - (3) [Reserved]

- (4) Caution signs. Standard color of the background shall be yellow; and the panel, black with yellow letters. Any letters used against the yellow background shall be black. The colors shall be those of opaque glossy samples as specified in Table 1 of American National Standard Z53.1-1967.
- (5) [Reserved]
- (6) Safety instruction signs. Standard color of the background shall be white; and the panel, green with white letters. Any letters used against the white background shall be black. The colors shall be those of opaque glossy samples as specified in Table 1 of American National Standard, Z53.1-1967.
- (7)-(9) [Reserved]
- (10) Slow-moving vehicle emblem. This emblem (see fig. J-7) consists of a fluorescent yellow-orange triangle with a dark red reflective border. The yellow-orange fluorescent triangle is a highly visible color for daylight exposure. The reflective border defines the shape of the fluorescent color in daylight and creates a hollow red triangle in the path of motor vehicle headlights at night. The emblem is intended as a unique identification for, and it shall be used only on, vehicles which by design move slowly (25 m.p.h. or less) on the public roads. The emblem is not a clearance marker for wide machinery nor is it intended to replace required lighting or marking of slow-moving vehicles. Neither the color film pattern and its dimensions nor the backing shall be altered to permit use of advertising or other markings. The material, location, mounting, etc., of the emblem shall be in accordance with the American Society of Agricultural Engineers Emblem for Identifying Slow-Moving Vehicles, ASAE R276, 1967, or ASAE S276.2 (ANSI B114.1-1971), which are incorporated by reference as specified in §1910.6.

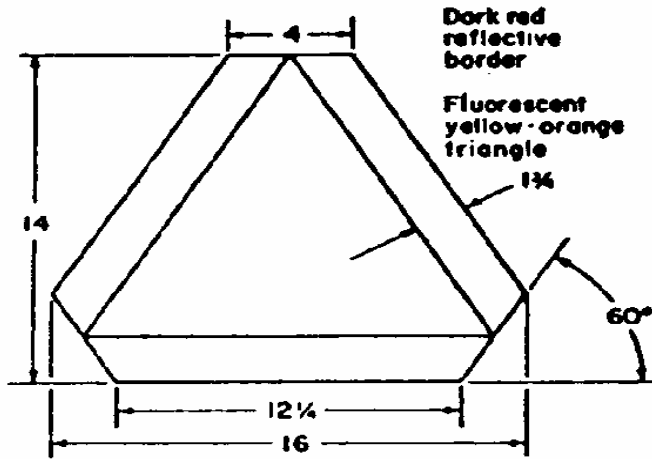

**FIGURE J-7.—SLOW-MOVING VEHICLE EMBLEM**

**NOTE: All dimensions are in inches.**

- (e) Sign wordings.
  - (1) [Reserved]
  - (2) Nature of wording. The wording of any sign should be easily read and concise. The sign should contain sufficient information to be easily understood. The wording should make a positive, rather than negative suggestion and should be accurate in fact.
  - (3) [Reserved]
  - (4) Biological hazard signs. The biological hazard warning shall be used to signify the actual or potential presence of a biohazard and to identify equipment, containers, rooms, materials, experimental animals, or combinations thereof, which contain, or are contaminated with, viable hazardous agents. For the purpose of this subparagraph the term "biological hazard," or "biohazard," shall include only those infectious agents presenting a risk or potential risk to the well-being of man.

- (f) Accident prevention tags.
- (1) Scope and application.
    - (i) This paragraph (f) applies to all accident prevention tags used to identify hazardous conditions and provide a message to employees with respect to hazardous conditions as set forth in paragraph (f)(3) of this section, or to meet the specific tagging requirements of other OSHA standards.
    - (ii) This paragraph (f) does not apply to construction, maritime or agriculture.
  - (2) Definitions.
 

**Biological hazard or BIOHAZARD** means those infectious agents presenting a risk of death, injury or illness to employees.

**Major message** means that portion of a tag's inscription that is more specific than the signal word and that indicates the specific hazardous condition or the instruction to be communicated to the employee. Examples include: "High Voltage," "Close Clearance," "Do Not Start," or "Do Not Use" or a corresponding pictograph used with a written text or alone.

**Pictograph** means a pictorial representation used to identify a hazardous condition or to convey a safety instruction.

**Signal word** means that portion of a tag's inscription that contains the word or words that are intended to capture the employee's immediate attention.

**Tag** means a device usually made of card, paper, pasteboard, plastic or other material used to identify a hazardous condition.
  - (3) Use. Tags shall be used as a means to prevent accidental injury or illness to employees who are exposed to hazardous or potentially hazardous conditions, equipment or operations which are out of the ordinary, unexpected or not readily apparent. Tags shall be used until such time as the identified hazard is eliminated or the hazardous operation is completed. Tags need not be used where signs, guarding or other positive means of protection are being used.
  - (4) General tag criteria. All required tags shall meet the following criteria:
    - (i) Tags shall contain a signal word and a major message.
      - (A) The signal word shall be either "Danger," "Caution," or "Biological Hazard," "BIOHAZARD," or the biological hazard symbol.
      - (B) The major message shall indicate the specific hazardous condition or the instruction to be communicated to the employee.
    - (ii) The signal word shall be readable at a minimum distance of five feet (1.52 m) or such greater distance as warranted by the hazard.
    - (iii) The tag's major message shall be presented in either pictographs, written text or both.
    - (iv) The signal word and the major message shall be understandable to all employees who may be exposed to the identified hazard.
    - (v) All employees shall be informed as to the meaning of the various tags used throughout the workplace and what special precautions are necessary.
    - (vi) Tags shall be affixed as close as safely possible to their respective hazards by a positive means such as string, wire, or adhesive that prevents their loss or unintentional removal.
  - (5) Danger tags. Danger tags shall be used in major hazard situations where an immediate hazard presents a threat of death or serious injury to employees. Danger tags shall be used only in these situations.
  - (6) Caution tags. Caution tags shall be used in minor hazard situations where a non-immediate or potential hazard or unsafe practice presents a lesser threat of employee injury. Caution tags shall be used only in these situations.
  - (7) Warning tags. Warning tags may be used to represent a hazard level between "Caution" and "Danger," instead of the required "Caution" tag, provided that they have a signal word of "Warning," an appropriate major message, and otherwise meet the general tag criteria of paragraph (f)(4) of this section.
  - (8) Biological hazard tags.
    - (i) Biological hazard tags shall be used to identify the actual or potential presence of a biological hazard and to identify equipment, containers, rooms, experimental animals, or combinations thereof, that contain or are contaminated with hazardous biological agents.
    - (ii) The symbol design for biological hazard tags shall conform to the design shown below:

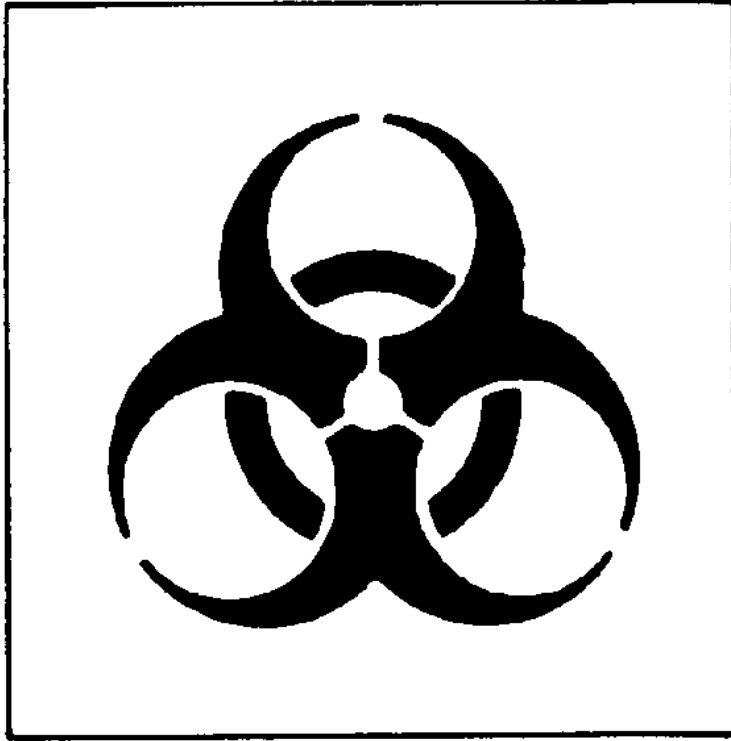

**Biological Hazard Symbol Configuration.**

- (9) Other tags. Other tags may be used in addition to those required by this paragraph (f), or in other situations where this paragraph (f) does not require tags, provided that they do not detract from the impact or visibility of the signal word and major message of any required tag.

**APPENDICES TO §1910.145(f), ACCIDENT PREVENTION TAGS**

**Appendix A to §1910.145(f)C**

**RECOMMENDED COLOR CODING**

While the standard does not specifically mandate colors to be used on accident prevention tags, the following color scheme is recommended by OSHA for meeting the requirements of this section:

"DANGER" - Red, or predominantly red, with lettering or symbols in a contrasting color.

"CAUTION" - Yellow, or predominantly yellow, with lettering or symbols in a contrasting color.

"WARNING" - Orange, or predominantly orange, with lettering or symbols in a contrasting color.

"BIOLOGICAL HAZARD" - Fluorescent orange or orange-red, or predominantly so, with lettering or symbols in a contrasting color.

**APPENDIX B TO §1910.145(f)C  
REFERENCES FOR FURTHER INFORMATION**

The following references provide information which can be helpful in understanding the requirements contained in various sections of the standard:

1. Bresnahan, Thomas F., and Bryk, Joseph, "The Hazard Association Values of Accident Prevention Signs", Journal of American Society of Safety Engineers; January 1975.
2. Dreyfuss, H., Symbol Sourcebook, McGraw Hill; New York, NY, 1972.
3. Glass, R.A. and others, Some Criteria for Colors and Signs in Workplaces, National Bureau of Standards, Washington DC, 1983.
4. Graphic Symbols for Public Areas and Occupational Environments, Treasury Board of Canada, Ottawa, Canada, July 1980.
5. Howett, G.L., Size of Letters Required for Visibility as a Function of Viewing Distance and Observer Acuity, National Bureau of Standards, Washington DC, July 1983.
6. Lerner, N.D. and Collins, B.L., The Assessment of Safety Symbol Understandability by Different Testing Methods, National Bureau of Standards, Washington DC, 1980.
7. Lerner, N.D. and Collins, B.L., Workplace Safety Symbols, National Bureau of Standards, Washington DC, 1980.
8. Modley, R. and Meyers, W. R., Handbook of Pictorial Symbols, Dover Publication, New York, NY, 1976.
9. Product Safety Signs and Labels, FMC Corporation, Santa Clara, CA, 1978.
10. Safety Color Coding for Marking Physical Hazards, Z53.1, American National Standards Institute, New York, NY, 1979.
11. Signs and Symbols for the Occupational Environment, Can. 3-Z-321-77, Canadian Standards Association, Ottawa, September 1977.
12. Symbols for Industrial Safety, National Bureau of Standards, Washington DC, April 1982.
13. Symbol Signs, U.S. Department of Transportation, Washington DC, November 1974.

**§1910.146 Permit-required confined spaces.**

(a) Scope and application. This section contains requirements for practices and procedures to protect employees in general industry from the hazards of entry into permit-required confined spaces. This section does not apply to agriculture, to construction, or to shipyard employment (Parts 1928, 1926, and 1915 of this chapter, respectively).

(b) Definitions.

**Acceptable entry conditions** means the conditions that must exist in a permit space to allow entry and to ensure that employees involved with a permit-required confined space entry can safely enter into and work within the space.

**Attendant** means an individual stationed outside one or more permit spaces who monitors the authorized entrants and who performs all attendant's duties assigned in the employer's permit space program.

**Authorized entrant** means an employee who is authorized by the employer to enter a permit space.

**Blanking or blinding** means the absolute closure of a pipe, line, or duct by the fastening of a solid plate (such as a spectacle blind or a skillet blind) that completely covers the bore and that is capable of withstanding the maximum pressure of the pipe, line, or duct with no leakage beyond the plate.

**Confined space** means a space that:

- (1) Is large enough and so configured that an employee can bodily enter and perform assigned work; and
- (2) Has limited or restricted means for entry or exit (for example, tanks, vessels, silos, storage bins, hoppers, vaults, and pits are spaces that may have limited means of entry.); and
- (3) Is not designed for continuous employee occupancy.

**Double block and bleed** means the closure of a line, duct, or pipe by closing and locking or tagging two in-line valves and by opening and locking or tagging a drain or vent valve in the line between the two closed valves.

**Emergency** means any occurrence (including any failure of hazard control or monitoring equipment) or event internal or external to the permit space that could endanger entrants.

**Engulfment** means the surrounding and effective capture of a person by a liquid or finely divided (flowable) solid substance that can be aspirated to cause death by filling or plugging the respiratory system or that can exert enough force on the body to cause death by strangulation, constriction, or crushing.

**Entry** means the action by which a person passes through an opening into a permit-required confined space. Entry includes ensuing work activities in that space and is considered to have occurred as soon as any part of the entrant's body breaks the plane of an opening into the space.

**Entry permit (permit)** means the written or printed document that is provided by the employer to allow and control entry into a permit space and that contains the information specified in paragraph (f) of this section.

**Entry supervisor** means the person (such as the employer, foreman, or crew chief) responsible for determining if acceptable entry conditions are present at a permit space where entry is planned, for authorizing entry and overseeing entry operations, and for terminating entry as required by this section.

**Note:** An entry supervisor also may serve as an attendant or as an authorized entrant, as long as that person is trained and equipped as required by this section for each role he or she fills. Also, the duties of entry supervisor may be passed from one individual to another during the course of an entry operation.

**Hazardous atmosphere** means an atmosphere that may expose employees to the risk of death, incapacitation, impairment of ability to self-rescue (that is, escape unaided from a permit space), injury, or acute illness from one or more of the following causes:

- (1) Flammable gas, vapor, or mist in excess of 10 percent of its lower flammable limit (LFL);
- (2) Airborne combustible dust at a concentration that meets or exceeds its LFL;

**Note:** This concentration may be approximated as a condition in which the dust obscures vision at a distance of 5 feet (1.52 m) or less.

- (3) Atmospheric oxygen concentration below 19.5 percent or above 23.5 percent;
- (4) Atmospheric concentration of any substance for which a dose or a permissible exposure limit is published in Subpart G, Occupational Health and Environmental Control, or in Subpart Z, Toxic and Hazardous Substances, of this part and which could result in employee exposure in excess of its dose or permissible exposure limit;

**Note:** An atmospheric concentration of any substance that is not capable of causing death, incapacitation, impairment of ability to self-rescue, injury, or acute illness due to its health effects is not covered by this provision.

- (5) Any other atmospheric condition that is immediately dangerous to life or health.

**Note:** For air contaminants for which OSHA has not determined a dose or permissible exposure limit, other sources of information, such as Material Safety Data Sheets that comply with the Hazard Communication Standard, §1910.1200 of this part, published information, and internal documents can provide guidance in establishing acceptable atmospheric conditions.

**Hot work permit** means the employer's written authorization to perform operations (for example, riveting, welding, cutting, burning, and heating) capable of providing a source of ignition.

**Immediately dangerous to life or health (IDLH)** means any condition that poses an immediate or delayed threat to life or that would cause irreversible adverse health effects or that would interfere with an individual's ability to escape unaided from a permit space.

**Note:** Some materials-hydrogen fluoride gas and cadmium vapor, for example-may produce immediate transient effects that, even if severe, may pass without medical attention, but are followed by sudden, possibly fatal collapse 12-72 hours after exposure. The victim "feels normal" from recovery from transient effects until collapse. Such materials in hazardous quantities are considered to be "immediately" dangerous to life or health.

**Inerting** means the displacement of the atmosphere in a permit space by a noncombustible gas (such as nitrogen) to such an extent that the resulting atmosphere is noncombustible.

**Note:** This procedure produces an IDLH oxygen-deficient atmosphere.

**Isolation** means the process by which a permit space is removed from service and completely protected against the release of energy and material into the space by such means as: blanking or blinding; misaligning or removing sections of lines, pipes, or ducts; a double block and bleed system; lockout or tagout of all sources of energy; or blocking or disconnecting all mechanical linkages.

**Line breaking** means the intentional opening of a pipe, line, or duct that is or has been carrying flammable, corrosive, or toxic material, an inert gas, or any fluid at a volume, pressure, or temperature capable of causing injury.

**Non-permit confined space** means a confined space that does not contain or, with respect to atmospheric hazards, have the potential to contain any hazard capable of causing death or serious physical harm.

**Oxygen deficient atmosphere** means an atmosphere containing less than 19.5 percent oxygen by volume.

**Oxygen enriched atmosphere** means an atmosphere containing more than 23.5 percent oxygen by volume.

**Permit-required confined space (permit space)** means a confined space that has one or more of the following characteristics:

- (1) Contains or has a potential to contain a hazardous atmosphere;
- (2) Contains a material that has the potential for engulfing an entrant;
- (3) Has an internal configuration such that an entrant could be trapped or asphyxiated by inwardly converging walls or by a floor which slopes downward and tapers to a smaller cross-section; or
- (4) Contains any other recognized serious safety or health hazard.

**Permit-required confined space program (permit space program)** means the employer's overall program for controlling, and, where appropriate, for protecting employees from, permit space hazards and for regulating employee entry into permit spaces.

**Permit system** means the employer's written procedure for preparing and issuing permits for entry and for returning the permit space to service following termination of entry.

**Prohibited condition** means any condition in a permit space that is not allowed by the permit during the period when entry is authorized.

**Rescue service** means the personnel designated to rescue employees from permit spaces.

**Retrieval system** means the equipment (including a retrieval line, chest or full-body harness, wristlets, if appropriate, and a lifting device or anchor) used for non-entry rescue of persons from permit spaces.

**Testing** means the process by which the hazards that may confront entrants of a permit space are identified and evaluated. Testing includes specifying the tests that are to be performed in the permit space.

**Note:** Testing enables employers both to devise and implement adequate control measures for the protection of authorized entrants and to determine if acceptable entry conditions are present immediately prior to, and during, entry.

**(c) General requirements.**

- (1) The employer shall evaluate the workplace to determine if any spaces are permit-required confined spaces.

**Note:** Proper application of the decision flow chart in appendix A to §1910.146 would facilitate compliance with this requirement.

- (2) If the workplace contains permit spaces, the employer shall inform exposed employees, by posting danger signs or by any other equally effective means, of the existence and location of and the danger posed by the permit spaces.

**Note:** A sign reading "DANGER-PERMIT-REQUIRED CONFINED SPACE, DO NOT ENTER" or using other similar language would satisfy the requirement for a sign.

- (3) If the employer decides that its employees will not enter permit spaces, the employer shall take effective measures to prevent its employees from entering the permit spaces and shall comply with paragraphs (c)(1), (c)(2), (c)(6), and (c)(8) of this section.
- (4) If the employer decides that its employees will enter permit spaces, the employer shall develop and implement a written permit space program that complies with this section. The written program shall be available for inspection by employees and their authorized representatives.
- (5) An employer may use the alternate procedures specified in paragraph (c)(5)(ii) of this section for entering a permit space under the conditions set forth in paragraph (c)(5)(i) of this section.
  - (i) An employer whose employees enter a permit space need not comply with paragraphs (d) through (f) and (h) through (k) of this section, provided that:
    - (A) The employer can demonstrate that the only hazard posed by the permit space is an actual or potential hazardous atmosphere;
    - (B) The employer can demonstrate that continuous forced air ventilation alone is sufficient to maintain that permit space safe for entry;

- (C) The employer develops monitoring and inspection data that supports the demonstrations required by paragraphs (c)(5)(i)(A) and (c)(5)(i)(B) of this section;
- (D) If an initial entry of the permit space is necessary to obtain the data required by paragraph (c)(5)(i)(C) of this section, the entry is performed in compliance with paragraphs (d) through (k) of this section;
- (E) The determinations and supporting data required by paragraphs (c)(5)(i)(A), (c)(5)(i)(B), and (c)(5)(i)(C) of this section are documented by the employer and are made available to each employee who enters the permit space under the terms of paragraph (c)(5) of this section or to that employee's authorized representative; and
- (F) Entry into the permit space under the terms of paragraph (c)(5)(i) of this section is performed in accordance with the requirements of paragraph (c)(5)(ii) of this section.

**Note:** See paragraph (c)(7) of this section for reclassification of a permit space after all hazards within the space have been eliminated.

- (ii) The following requirements apply to entry into permit spaces that meet the conditions set forth in paragraph (c)(5)(i) of this section.
  - (A) Any conditions making it unsafe to remove an entrance cover shall be eliminated before the cover is removed.
  - (B) When entrance covers are removed, the opening shall be promptly guarded by a railing, temporary cover, or other temporary barrier that will prevent an accidental fall through the opening and that will protect each employee working in the space from foreign objects entering the space.
  - (C) Before an employee enters the space, the internal atmosphere shall be tested, with a calibrated direct-reading instrument, for oxygen content, for flammable gases and vapors, and for potential toxic air contaminants, in that order. Any employee who enters the space, or that employee's authorized representative, shall be provided an opportunity to observe the pre-entry testing required by this paragraph.
  - (D) There may be no hazardous atmosphere within the space whenever any employee is inside the space.
  - (E) Continuous forced air ventilation shall be used, as follows:
    - (1) An employee may not enter the space until the forced air ventilation has eliminated any hazardous atmosphere;
    - (2) The forced air ventilation shall be so directed as to ventilate the immediate areas where an employee is or will be present within the space and shall continue until all employees have left the space;
    - (3) The air supply for the forced air ventilation shall be from a clean source and may not increase the hazards in the space.
  - (F) The atmosphere within the space shall be periodically tested as necessary to ensure that the continuous forced air ventilation is preventing the accumulation of a hazardous atmosphere. Any employee who enters the space, or that employee's authorized representative, shall be provided with an opportunity to observe the periodic testing required by this paragraph.
  - (G) If a hazardous atmosphere is detected during entry:
    - (1) Each employee shall leave the space immediately;
    - (2) The space shall be evaluated to determine how the hazardous atmosphere developed; and
    - (3) Measures shall be implemented to protect employees from the hazardous atmosphere before any subsequent entry takes place.
  - (H) The employer shall verify that the space is safe for entry and that the pre-entry measures required by paragraph (c)(5)(ii) of this section have been taken, through a written certification that contains the date, the location of the space, and the signature of the person providing the certification. The certification shall be made before entry and shall be made available to each employee entering the space or to that employee's authorized representative.
- (6) When there are changes in the use or configuration of a non-permit confined space that might increase the hazards to entrants, the employer shall reevaluate that space and, if necessary, reclassify it as a permit-required confined space.



- (7) A space classified by the employer as a permit-required confined space may be reclassified as a non-permit confined space under the following procedures:
- (i) If the permit space poses no actual or potential atmospheric hazards and if all hazards within the space are eliminated without entry into the space, the permit space may be reclassified as a non-permit confined space for as long as the non-atmospheric hazards remain eliminated.
  - (ii) If it is necessary to enter the permit space to eliminate hazards, such entry shall be performed under paragraphs (d) through (k) of this section. If testing and inspection during that entry demonstrate that the hazards within the permit space have been eliminated, the permit space may be reclassified as a non-permit confined space for as long as the hazards remain eliminated.

**Note:** Control of atmospheric hazards through forced air ventilation does not constitute elimination of the hazards. Paragraph (c)(5) covers permit space entry where the employer can demonstrate that forced air ventilation alone will control all hazards in the space.

- (iii) The employer shall document the basis for determining that all hazards in a permit space have been eliminated, through a certification that contains the date, the location of the space, and the signature of the person making the determination. The certification shall be made available to each employee entering the space or to that employee's authorized representative.
  - (iv) If hazards arise within a permit space that has been declassified to a non-permit space under paragraph (c)(7) of this section, each employee in the space shall exit the space. The employer shall then reevaluate the space and determine whether it must be reclassified as a permit space, in accordance with other applicable provisions of this section.
- (8) When an employer (host employer) arranges to have employees of another employer (contractor) perform work that involves permit space entry, the host employer shall:
- (i) Inform the contractor that the workplace contains permit spaces and that permit space entry is allowed only through compliance with a permit space program meeting the requirements of this section;
  - (ii) Apprise the contractor of the elements, including the hazards identified and the host employer's experience with the space, that make the space in question a permit space;
  - (iii) Apprise the contractor of any precautions or procedures that the host employer has implemented for the protection of employees in or near permit spaces where contractor personnel will be working;
  - (iv) Coordinate entry operations with the contractor, when both host employer personnel and contractor personnel will be working in or near permit spaces, as required by paragraph (d)(11) of this section; and
  - (v) Debrief the contractor at the conclusion of the entry operations regarding the permit space program followed and regarding any hazards confronted or created in permit spaces during entry operations.
- (9) In addition to complying with the permit space requirements that apply to all employers, each contractor who is retained to perform permit space entry operations shall:
- (i) Obtain any available information regarding permit space hazards and entry operations from the host employer;
  - (ii) Coordinate entry operations with the host employer, when both host employer personnel and contractor personnel will be working in or near permit spaces, as required by paragraph (d)(11) of this section; and
  - (iii) Inform the host employer of the permit space program that the contractor will follow and of any hazards confronted or created in permit spaces, either through a debriefing or during the entry operation.
- (d) Permit-required confined space program (permit space program).** Under the permit space program required by paragraph (c)(4) of this section, the employer shall:
- (1) Implement the measures necessary to prevent unauthorized entry;
  - (2) Identify and evaluate the hazards of permit spaces before employees enter them;
  - (3) Develop and implement the means, procedures, and practices necessary for safe permit space entry operations, including, but not limited to, the following:

- (i) Specifying acceptable entry conditions;
  - (ii) Providing each authorized entrant or that employee's authorized representative with the opportunity to observe any monitoring or testing of permit spaces;
  - (iii) Isolating the permit space;
  - (iv) Purging, inerting, flushing, or ventilating the permit space as necessary to eliminate or control atmospheric hazards;
  - (v) Providing pedestrian, vehicle, or other barriers as necessary to protect entrants from external hazards; and
  - (vi) Verifying that conditions in the permit space are acceptable for entry throughout the duration of an authorized entry.
- (4) Provide the following equipment (specified in paragraphs (d)(4)(i) through (d)(4)(ix) of this section) at no cost to employees, maintain that equipment properly, and ensure that employees use that equipment properly:
- (i) Testing and monitoring equipment needed to comply with paragraph (d)(5) of this section;
  - (ii) Ventilating equipment needed to obtain acceptable entry conditions;
  - (iii) Communications equipment necessary for compliance with paragraphs (h)(3) and (i)(5) of this section;
  - (iv) Personal protective equipment insofar as feasible engineering and work practice controls do not adequately protect employees;
  - (v) Lighting equipment needed to enable employees to see well enough to work safely and to exit the space quickly in an emergency;
  - (vi) Barriers and shields as required by paragraph (d)(3)(iv) of this section;
  - (vii) Equipment, such as ladders, needed for safe ingress and egress by authorized entrants;
  - (viii) Rescue and emergency equipment needed to comply with paragraph (d)(9) of this section, except to the extent that the equipment is provided by rescue services; and
  - (ix) Any other equipment necessary for safe entry into and rescue from permit spaces.
- (5) Evaluate permit space conditions as follows when entry operations are conducted:
- (i) Test conditions in the permit space to determine if acceptable entry conditions exist before entry is authorized to begin, except that, if isolation of the space is infeasible because the space is large or is part of a continuous system (such as a sewer), pre-entry testing shall be performed to the extent feasible before entry is authorized and, if entry is authorized, entry conditions shall be continuously monitored in the areas where authorized entrants are working;
  - (ii) Test or monitor the permit space as necessary to determine if acceptable entry conditions are being maintained during the course of entry operations; and
  - (iii) When testing for atmospheric hazards, test first for oxygen, then for combustible gases and vapors, and then for toxic gases and vapors.
  - (iv) Provide each authorized entrant or that employee's authorized representative an opportunity to observe the pre-entry and any subsequent testing or monitoring of permit spaces;
  - (v) Reevaluate the permit space in the presence of any authorized entrant or that employee's authorized representative who requests that the employer conduct such reevaluation because the entrant or representative has reason to believe that the evaluation of that space may not have been adequate;
  - (vi) Immediately provide each authorized entrant or that employee's authorized representative with the results of any testing conducted in accord with paragraph (d) of this section.

**Comment [COMMENT1]:**  
1910.146(d)(5)(v)

**Note:** Atmospheric testing conducted in accordance with Appendix B to §1910.146 would be considered as satisfying the requirements of this paragraph. For permit space operations in sewers, atmospheric testing conducted in accordance with appendix B, as supplemented by appendix E to §1910.146, would be considered as satisfying the requirements of this paragraph.

- (6) Provide at least one attendant outside the permit space into which entry is authorized for the duration of entry operations;

**Note:** Attendants may be assigned to monitor more than one permit space provided the duties described in paragraph (i) of this section can be effectively performed for each permit space that is monitored. Likewise, attendants may be stationed at any location outside the permit space to be monitored as long as the duties described in paragraph (i) of this section can be effectively performed for each permit space that is monitored.

- (7) If multiple spaces are to be monitored by a single attendant, include in the permit program the means and procedures to enable the attendant to respond to an emergency affecting one or more of the permit spaces being monitored without distraction from the attendant's responsibilities under paragraph (i) of this section;
- (8) Designate the persons who are to have active roles (as, for example, authorized entrants, attendants, entry supervisors, or persons who test or monitor the atmosphere in a permit space) in entry operations, identify the duties of each such employee, and provide each such employee with the training required by paragraph (g) of this section;
- (9) Develop and implement procedures for summoning rescue and emergency services, for rescuing entrants from permit spaces, for providing necessary emergency services to rescued employees, and for preventing unauthorized personnel from attempting a rescue;
- (10) Develop and implement a system for the preparation, issuance, use, and cancellation of entry permits as required by this section;
- (11) Develop and implement procedures to coordinate entry operations when employees of more than one employer are working simultaneously as authorized entrants in a permit space, so that employees of one employer do not endanger the employees of any other employer;
- (12) Develop and implement procedures (such as closing off a permit space and canceling the permit) necessary for concluding the entry after entry operations have been completed;
- (13) Review entry operations when the employer has reason to believe that the measures taken under the permit space program may not protect employees and revise the program to correct deficiencies found to exist before subsequent entries are authorized; and

**Note:** Examples of circumstances requiring the review of the permit space program are: any unauthorized entry of a permit space, the detection of a permit space hazard not covered by the permit, the detection of a condition prohibited by the permit, the occurrence of an injury or near-miss during entry, a change in the use or configuration of a permit space, and employee complaints about the effectiveness of the program.

- (14) Review the permit space program, using the canceled permits retained under paragraph (e)(6) of this section within 1 year after each entry and revise the program as necessary, to ensure that employees participating in entry operations are protected from permit space hazards.

**Note:** Employers may perform a single annual review covering all entries performed during a 12-month period. If no entry is performed during a 12-month period, no review is necessary.

Appendix C to §1910.146 presents examples of permit space programs that are considered to comply with the requirements of paragraph (d) of this section.

**(e) Permit system.**

- (1) Before entry is authorized, the employer shall document the completion of measures required by paragraph (d)(3) of this section by preparing an entry permit.

**Note:** Appendix D to §1910.146 presents examples of permits whose elements are considered to comply with the requirements of this section.

- (2) Before entry begins, the entry supervisor identified on the permit shall sign the entry permit to authorize entry.
- (3) The completed permit shall be made available at the time of entry to all authorized entrants or their authorized representatives, by posting it at the entry portal or by any other equally effective means, so that the entrants can confirm that pre-entry preparations have been completed.
- (4) The duration of the permit may not exceed the time required to complete the assigned task or job identified on the permit in accordance with paragraph (f)(2) of this section.
- (5) The entry supervisor shall terminate entry and cancel the entry permit when:
  - (i) The entry operations covered by the entry permit have been completed; or
  - (ii) A condition that is not allowed under the entry permit arises in or near the permit space.
- (6) The employer shall retain each canceled entry permit for at least 1 year to facilitate the review of the permit-required confined space program required by paragraph (d)(14) of this section. Any problems encountered during an entry operation shall be noted on the pertinent permit so that appropriate revisions to the permit space program can be made.

**(f) Entry permit.** The entry permit that documents compliance with this section and authorizes entry to a permit space shall identify:

- (1) The permit space to be entered;
- (2) The purpose of the entry;
- (3) The date and the authorized duration of the entry permit;

- (4) The authorized entrants within the permit space, by name or by such other means (for example, through the use of rosters or tracking systems) as will enable the attendant to determine quickly and accurately, for the duration of the permit, which authorized entrants are inside the permit space;

**Note:** This requirement may be met by inserting a reference on the entry permit as to the means used, such as a roster or tracking system, to keep track of the authorized entrants within the permit space.

- (5) The personnel, by name, currently serving as attendants;
- (6) The individual, by name, currently serving as entry supervisor, with a space for the signature or initials of the entry supervisor who originally authorized entry;
- (7) The hazards of the permit space to be entered;
- (8) The measures used to isolate the permit space and to eliminate or control permit space hazards before entry;

**Note:** Those measures can include the lockout or tagging of equipment and procedures for purging, inerting, ventilating, and flushing permit spaces.

- (9) The acceptable entry conditions;
- (10) The results of initial and periodic tests performed under paragraph (d)(5) of this section, accompanied by the names or initials of the testers and by an indication of when the tests were performed;
- (11) The rescue and emergency services that can be summoned and the means (such as the equipment to use and the numbers to call) for summoning those services;
- (12) The communication procedures used by authorized entrants and attendants to maintain contact during the entry;
- (13) Equipment, such as personal protective equipment, testing equipment, communications equipment, alarm systems, and rescue equipment, to be provided for compliance with this section;
- (14) Any other information whose inclusion is necessary, given the circumstances of the particular confined space, in order to ensure employee safety; and
- (15) Any additional permits, such as for hot work, that have been issued to authorize work in the permit space.

**(g) Training.**

- (1) The employer shall provide training so that all employees whose work is regulated by this section acquire the understanding, knowledge, and skills necessary for the safe performance of the duties assigned under this section.
- (2) Training shall be provided to each affected employee:
  - (i) Before the employee is first assigned duties under this section;
  - (ii) Before there is a change in assigned duties;
  - (iii) Whenever there is a change in permit space operations that presents a hazard about which an employee has not previously been trained;
  - (iv) Whenever the employer has reason to believe either that there are deviations from the permit space entry procedures required by paragraph (d)(3) of this section or that there are inadequacies in the employee's knowledge or use of these procedures.
- (3) The training shall establish employee proficiency in the duties required by this section and shall introduce new or revised procedures, as necessary, for compliance with this section.
- (4) The employer shall certify that the training required by paragraphs (g)(1) through (g)(3) of this section has been accomplished. The certification shall contain each employee's name, the signatures or initials of the trainers, and the dates of training. The certification shall be available for inspection by employees and their authorized representatives.

**(h) Duties of authorized entrants.** The employer shall ensure that all authorized entrants:

- (1) Know the hazards that may be faced during entry, including information on the mode, signs or symptoms, and consequences of the exposure;
- (2) Properly use equipment as required by paragraph (d)(4) of this section;
- (3) Communicate with the attendant as necessary to enable the attendant to monitor entrant status and to enable the attendant to alert entrants of the need to evacuate the space as required by paragraph (i)(6) of this section;
- (4) Alert the attendant whenever:

- (i) The entrant recognizes any warning sign or symptom of exposure to a dangerous situation, or
- (ii) The entrant detects a prohibited condition; and
- (5) Exit from the permit space as quickly as possible whenever:
  - (i) An order to evacuate is given by the attendant or the entry supervisor,
  - (ii) The entrant recognizes any warning sign or symptom of exposure to a dangerous situation,
  - (iii) The entrant detects a prohibited condition, or
  - (iv) An evacuation alarm is activated.

**(i) Duties of attendants.** The employer shall ensure that each attendant:

- (1) Knows the hazards that may be faced during entry, including information on the mode, signs or symptoms, and consequences of the exposure;
- (2) Is aware of possible behavioral effects of hazard exposure in authorized entrants;
- (3) Continuously maintains an accurate count of authorized entrants in the permit space and ensures that the means used to identify authorized entrants under paragraph (f)(4) of this section accurately identifies who is in the permit space;
- (4) Remains outside the permit space during entry operations until relieved by another attendant;

**Note:** When the employer's permit entry program allows attendant entry for rescue, attendants may enter a permit space to attempt a rescue if they have been trained and equipped for rescue operations as required by paragraph (k)(1) of this section and if they have been relieved as required by paragraph (i)(4) of this section.

- (5) Communicates with authorized entrants as necessary to monitor entrant status and to alert entrants of the need to evacuate the space under paragraph (i)(6) of this section;
- (6) Monitors activities inside and outside the space to determine if it is safe for entrants to remain in the space and orders the authorized entrants to evacuate the permit space immediately under any of the following conditions:
  - (i) If the attendant detects a prohibited condition;
  - (ii) If the attendant detects the behavioral effects of hazard exposure in an authorized entrant;
  - (iii) If the attendant detects a situation outside the space that could endanger the authorized entrants; or
  - (iv) If the attendant cannot effectively and safely perform all the duties required under paragraph (i) of this section;
- (7) Summon rescue and other emergency services as soon as the attendant determines that authorized entrants may need assistance to escape from permit space hazards;
- (8) Takes the following actions when unauthorized persons approach or enter a permit space while entry is underway:
  - (i) Warn the unauthorized persons that they must stay away from the permit space;
  - (ii) Advise the unauthorized persons that they must exit immediately if they have entered the permit space; and
  - (iii) Inform the authorized entrants and the entry supervisor if unauthorized persons have entered the permit space;
- (9) Performs non-entry rescues as specified by the employer's rescue procedure; and
- (10) Performs no duties that might interfere with the attendant's primary duty to monitor and protect the authorized entrants.

**(j) Duties of entry supervisors.** The employer shall ensure that each entry supervisor:

- (1) Knows the hazards that may be faced during entry, including information on the mode, signs or symptoms, and consequences of the exposure;
- (2) Verifies, by checking that the appropriate entries have been made on the permit, that all tests specified by the permit have been conducted and that all procedures and equipment specified by the permit are in place before endorsing the permit and allowing entry to begin;
- (3) Terminates the entry and cancels the permit as required by paragraph (e)(5) of this section;
- (4) Verifies that rescue services are available and that the means for summoning them are operable;
- (5) Removes unauthorized individuals who enter or who attempt to enter the permit space during entry operations; and
- (6) Determines, whenever responsibility for a permit space entry operation is transferred and at intervals dictated by the hazards and operations performed within the space, that entry

operations remain consistent with terms of the entry permit and that acceptable entry conditions are maintained.

**(k) Rescue and emergency services.**

- (1) An employer who designates rescue and emergency services, pursuant to paragraph (d)(9) of this section, shall:
- (i) Evaluate a prospective rescuer's ability to respond to a rescue summons in a timely manner, considering the hazard(s) identified;

**Note to paragraph (k)(1)(i):** What will be considered timely will vary according to the specific hazards involved in each entry. For example, §1910.134, Respiratory Protection, requires that employers provide a standby person or persons capable of immediate action to rescue employee(s) wearing respiratory protection while in work areas defined as IDLH atmospheres.

- (ii) Evaluate a prospective rescue service's ability, in terms of proficiency with rescue-related tasks and equipment, to function appropriately while rescuing entrants from the particular permit space or types of permit spaces identified;
- (iii) Select a rescue team or service from those evaluated that:
- (A) Has the capability to reach the victim(s) within a time frame that is appropriate for the permit space hazard(s) identified;
- (B) Is equipped for and proficient in performing the needed rescue services;
- (iv) Inform each rescue team or service of the hazards they may confront when called on to perform rescue at the site; and
- (v) Provide the rescue team or service selected with access to all permit spaces from which rescue may be necessary so that the rescue service can develop appropriate rescue plans and practice rescue operations.

**Note to paragraph (k)(1):** Non-mandatory Appendix F contains examples of criteria which employers can use in evaluating prospective rescuers as required by paragraph (k)(1) of this section.

- (2) An employer whose employees have been designated to provide permit space rescue and emergency services shall take the following measures:
- (i) Provide affected employees with the personal protective equipment (PPE) needed to conduct permit space rescues safely and train affected employees so they are proficient in the use of that PPE, at no cost to those employees;
- (ii) Train affected employees to perform assigned rescue duties. The employer must ensure that such employees successfully complete the training required to establish proficiency as an authorized entrant, as provided by paragraphs (g) and (h) of this section;
- (iii) Train affected employees in basic first-aid and cardiopulmonary resuscitation (CPR). The employer shall ensure that at least one member of the rescue team or service holding a current certification in first aid and CPR is available; and
- (iv) Ensure that affected employees practice making permit space rescues at least once every 12 months, by means of simulated rescue operations in which they remove dummies, manikins, or actual persons from the actual permit spaces or from representative permit spaces. Representative permit spaces shall, with respect to opening size, configuration, and accessibility, simulate the types of permit spaces from which rescue is to be performed.
- (3) To facilitate non-entry rescue, retrieval systems or methods shall be used whenever an authorized entrant enters a permit space, unless the retrieval equipment would increase the overall risk of entry or would not contribute to the rescue of the entrant. Retrieval systems shall meet the following requirements.
- (i) Each authorized entrant shall use a chest or full body harness, with a retrieval line attached at the center of the entrant's back near shoulder level, above the entrant's head, or at another point which the employer can establish presents a profile small enough for the successful removal of the entrant. Wristlets may be used in lieu of the chest or full body harness if the employer can demonstrate that the use of a chest or full body harness is infeasible or creates a greater hazard and that the use of wristlets is the safest and most effective alternative.
- (ii) The other end of the retrieval line shall be attached to a mechanical device or fixed point outside the permit space in such a manner that rescue can begin as soon as the rescuer becomes aware that rescue is necessary. A mechanical device shall be available to retrieve personnel from vertical type permit spaces more than 5 feet (1.52 m) deep.

**Comment [COMMENT2]:**  
1910.146(k)(3)(ii)

- (4) If an injured entrant is exposed to a substance for which a Material Safety Data Sheet (MSDS) or other similar written information is required to be kept at the worksite, that MSDS or written information shall be made available to the medical facility treating the exposed entrant.
- (I) Employee participation.
  - (1) Employers shall consult with affected employees and their authorized representatives on the development and implementation of all aspects of the permit space program required by paragraph (c) of this section.
  - (2) Employers shall make available to affected employees and their authorized representatives all information required to be developed by this section.

**APPENDICES TO §1910.146  
PERMIT-REQUIRED CONFINED SPACES**

**Note:** Appendices A through F serve to provide information and non-mandatory guidelines to assist employers and employees in complying with the appropriate requirements of this section.



APPENDIX A TO §1910.146—PERMIT-REQUIRED CONFINED SPACE DECISION FLOW CHART

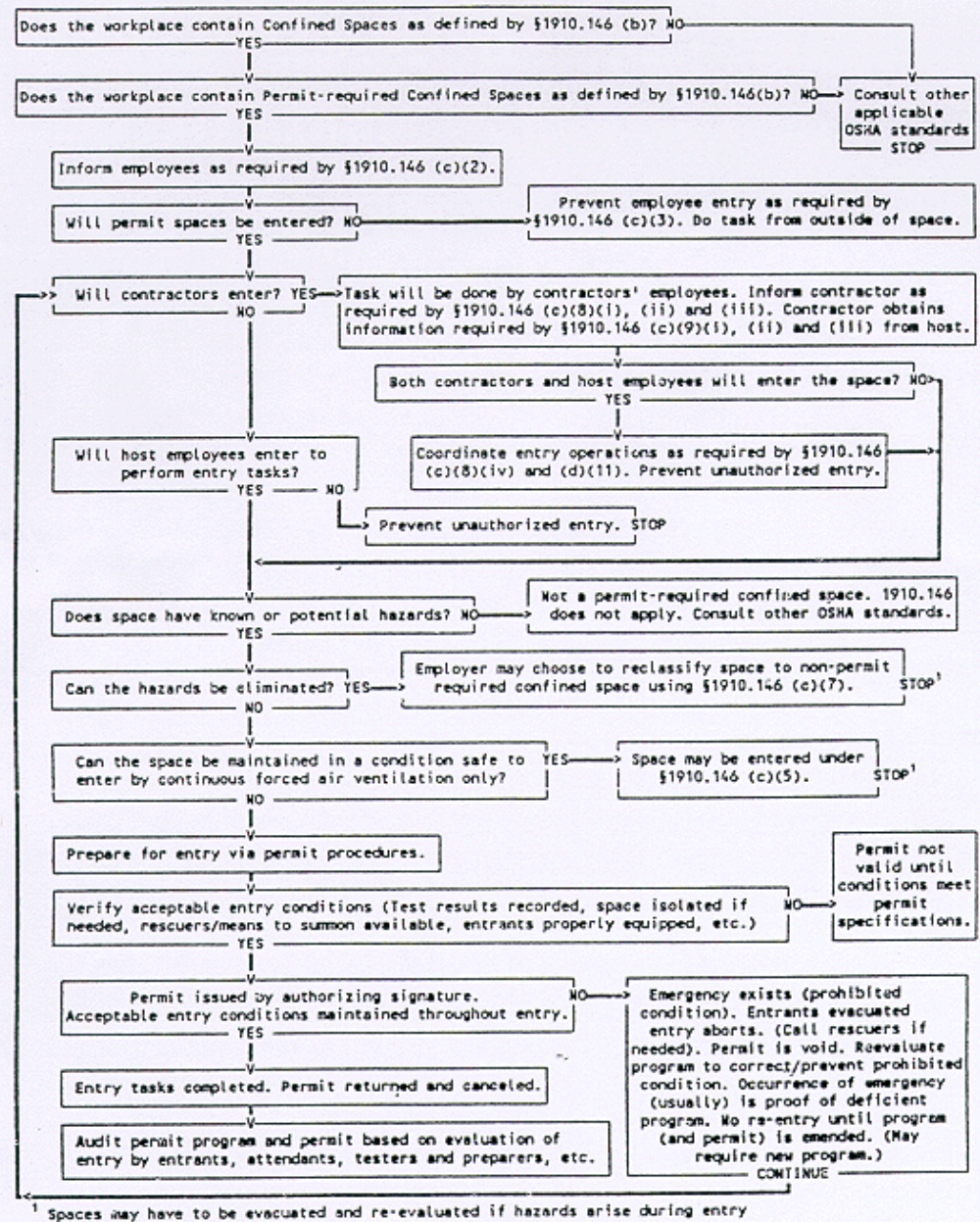

Note: Appendices A through F serve to provide information and non-mandatory guidelines to assist employers and employees in complying with the appropriate requirements of this section.



**APPENDIX B TO §1910.146  
PROCEDURES FOR ATMOSPHERIC TESTING**

Atmospheric testing is required for two distinct purposes: evaluation of the hazards of the permit space and verification that acceptable entry conditions for entry into that space exist.

- (1) **Evaluation testing.** The atmosphere of a confined space should be analyzed using equipment of sufficient sensitivity and specificity to identify and evaluate any hazardous atmospheres that may exist or arise, so that appropriate permit entry procedures can be developed and acceptable entry conditions stipulated for that space. Evaluation and interpretation of these data, and development of the entry procedure, should be done by, or reviewed by, a technically qualified professional (e.g., OSHA consultation service, or certified industrial hygienist, registered safety engineer, certified safety professional, certified marine chemist, etc.) based on evaluation of all serious hazards.
- (2) **Verification testing.** The atmosphere of a permit space which may contain a hazardous atmosphere should be tested for residues of all contaminants identified by evaluation testing using permit specified equipment to determine that residual concentrations at the time of testing and entry are within the range of acceptable entry conditions. Results of testing (i.e., actual concentration, etc.) should be recorded on the permit in the space provided adjacent to the stipulated acceptable entry conditions.
- (3) **Duration of testing.** Measurement of values for each atmospheric parameter should be made for at least the minimum response time of the test instrument specified by the manufacturer.
- (4) **Testing stratified atmospheres.** When monitoring for entries involving a descent into atmospheres that may be stratified, the atmospheric envelope should be tested a distance of approximately 4 feet (1.22 m) in the direction of travel and to each side. If a sampling probe is used, the entrant's rate of progress should be slowed to accommodate the sampling speed and detector response.
- (5) **Order of testing.** A test for oxygen is performed first because most combustible gas meters are oxygen dependent and will not provide reliable readings in an oxygen deficient atmosphere. Combustible gases are tested for next because the threat of fire or explosion is both more immediate and more life threatening, in most cases, than exposure to toxic gases and vapors. If tests for toxic gases and vapors are necessary, they are performed last.

**APPENDIX C TO §1910.146  
EXAMPLES OF PERMIT-REQUIRED CONFINED SPACE PROGRAMS**

Example 1.

**Workplace.** Sewer entry.

**Potential hazards.** The employees could be exposed to the following:

**Engulfment.**

**Presence of toxic gases.** Equal to or more than 10 ppm hydrogen sulfide measured as an 8-hour time-weighted average. If the presence of other toxic contaminants is suspected, specific monitoring programs will be developed.

**Presence of explosive/flammable gases.** Equal to or greater than 10% of the lower flammable limit (LFL).

**Oxygen Deficiency.** A concentration of oxygen in the atmosphere equal to or less than 19.5% by volume.

**A. Entry Without Permit/Attendant**

**Certification.** Confined spaces may be entered without the need for a written permit or attendant provided that the space can be maintained in a safe condition for entry by mechanical ventilation alone, as provided in §1910.146(c)(5). All spaces shall be considered permit-required confined spaces until the pre-entry procedures demonstrate otherwise. Any employee required or permitted to pre-check or enter an enclosed/confined space shall have successfully completed, as a minimum, the training as required by the following sections of these procedures. A written copy of operating and rescue procedures as required by these procedures shall be at the work site for the duration of the job. The Confined Space Pre-Entry Check List must be completed by the LEAD WORKER before entry into a confined space. This list verifies completion of items listed below. This

check list shall be kept at the job site for duration of the job. If circumstances dictate an interruption in the work, the permit space must be re-evaluated and a new check list must be completed.

**Control of atmospheric and engulfment hazards.**

**Pumps and Lines.** All pumps and lines which may reasonably cause contaminants to flow into the space shall be disconnected, blinded and locked out, or effectively isolated by other means to prevent development of dangerous air contamination or engulfment. Not all laterals to sewers or storm drains require blocking. However, where experience or knowledge of industrial use indicates there is a reasonable potential for contamination of air or engulfment into an occupied sewer, then all affected laterals shall be blocked. If blocking and/or isolation requires entry into the space the provisions for entry into a permit-required confined space must be implemented.

**Surveillance.** The surrounding area shall be surveyed to avoid hazards such as drifting vapors from the tanks, piping, or sewers.

**Testing.** The atmosphere within the space will be tested to determine whether dangerous air contamination and/or oxygen deficiency exists. Detector tubes, alarm only gas monitors and explosion meters are examples of monitoring equipment that may be used to test permit space atmospheres. Testing shall be performed by the LEAD WORKER who has successfully completed the Gas Detector training for the monitor he will use. The minimum parameters to be monitored are oxygen deficiency, LFL, and hydrogen sulfide concentration. A written record of the pre-entry test results shall be made and kept at the work site for the duration of the job. The supervisor will certify in writing, based upon the results of the pre-entry testing, that all hazards have been eliminated. Affected employees shall be able to review the testing results. The most hazardous conditions shall govern when work is being performed in two adjoining, connecting spaces.

**Entry Procedures.** If there are no non-atmospheric hazards present and if the pre-entry tests show there is no dangerous air contamination and/or oxygen deficiency within the space and there is no reason to believe that any is likely to develop, entry into and work within may proceed. Continuous testing of the atmosphere in the immediate vicinity of the workers within the space shall be accomplished. The workers will immediately leave the permit space when any of the gas monitor alarm set points are reached as defined. Workers will not return to the area until a SUPERVISOR who has completed the gas detector training has used a direct reading gas detector to evaluate the situation and has determined that it is safe to enter.

**Rescue.** Arrangements for rescue services are not required where there is no attendant. See the rescue portion of section B., below, for instructions regarding rescue planning where an entry permit is required.

**B. Entry Permit Required**

**Permits.** Confined Space Entry Permit. All spaces shall be considered permit-required confined spaces until the pre-entry procedures demonstrate otherwise. Any employee required or permitted to pre-check or enter a permit-required confined space shall have successfully completed, as a minimum, the training as required by the following sections of these procedures. A written copy of operating and rescue procedures as required by these procedures shall be at the work site for the duration of the job. The Confined Space Entry Permit must be completed before approval can be given to enter a permit-required confined space. This permit verifies completion of items listed below.

This permit shall be kept at the job site for the duration of the job. If circumstances cause an interruption in the work or a change in the alarm conditions for which entry was approved, a new Confined Space Entry Permit must be completed.

**Control of atmospheric and engulfment hazards.**

**Surveillance.** The surrounding area shall be surveyed to avoid hazards such as drifting vapors from tanks, piping or sewers.

**Testing.** The confined space atmosphere shall be tested to determine whether dangerous air contamination and/or oxygen deficiency exists. A direct reading gas monitor shall be used. Testing shall be performed by the SUPERVISOR who has successfully completed the gas detector training for the monitor he will use. The minimum parameters to be monitored are oxygen deficiency, LFL and hydrogen sulfide concentration. A written record of the pre-entry test results shall be made and kept at the work site for the duration of the job. Affected employees shall be able to review the testing results. The most hazardous conditions shall govern when work is being performed in two adjoining, connected spaces.

**Space Ventilation.** Mechanical ventilation systems, where applicable, shall be set at 100% outside air. Where possible, open additional manholes to increase air circulation. Use portable blowers to augment natural circulation if needed. After a suitable ventilating period, repeat the testing. Entry may not begin until testing has demonstrated that the hazardous atmosphere has been eliminated.

**Entry Procedures.** The following procedure shall be observed under any of the following conditions: 1.) Testing demonstrates the existence of dangerous or deficient conditions and additional ventilation cannot reduce concentrations to safe levels; 2.) The atmosphere tests as safe but unsafe conditions can reasonably be expected to develop; 3.) It is not feasible to provide for ready exit from spaces equipped with automatic fire suppression systems and it is not practical or safe to deactivate such systems; or 4.) An emergency exists and it is not feasible to wait for pre-entry procedures to take effect.

All personnel must be trained. A self contained breathing apparatus shall be worn by any person entering the space. At least one worker shall stand by the outside of the space ready to give assistance in case of emergency. The standby worker shall have a self contained breathing apparatus available for immediate use. There shall be at least one additional worker within sight or call of the standby worker. Continuous powered communications shall be maintained between the worker within the confined space and standby personnel.

If at any time there is any questionable action or non-movement by the worker inside, a verbal check will be made. If there is no response, the worker will be moved immediately. Exception: If the worker is disabled due to falling or impact, he/she shall not be removed from the confined space unless there is immediate danger to his/her life. Local fire department rescue personnel shall be notified immediately. The standby worker may only enter the confined space in case of an emergency (wearing the self contained breathing apparatus) and only after being relieved by another worker. Safety belt or harness with attached lifeline shall be used by all workers entering the space with the free end of the line secured outside the entry opening. The standby worker shall attempt to remove a disabled worker via his lifeline before entering the space.

When practical, these spaces shall be entered through side openings-those within 3 1/2 feet (1.07 m) of the bottom. When entry must be through a top opening, the safety belt shall be of the harness type that suspends a person upright and a hoisting device or similar apparatus shall be available for lifting workers out of the space.

In any situation where their use may endanger the worker, use of a hoisting device or safety belt and attached lifeline may be discontinued.

When dangerous air contamination is attributable to flammable and/or explosive substances, lighting and electrical equipment shall be Class 1, Division 1 rated per National Electrical Code and no ignition sources shall be introduced into the area.

Continuous gas monitoring shall be performed during all confined space operations. If alarm conditions change adversely, entry personnel shall exit the confined space and a new confined space permit issued.

**Rescue.** Call the fire department services for rescue. Where immediate hazards to injured personnel are present, workers at the site shall implement emergency procedures to fit the situation.

#### Example 2.

**Workplace.** Meat and poultry rendering plants.

Cookers and dryers are either batch or continuous in their operation. Multiple batch cookers are operated in parallel. When one unit of a multiple set is shut down for repairs, means are available to isolate that unit from the others which remain in operation.

Cookers and dryers are horizontal, cylindrical vessels equipped with a center, rotating shaft and agitator paddles or discs. If the inner shell is jacketed, it is usually heated with steam at pressures up to 150 psig (1034.25 kPa). The rotating shaft assembly of the continuous cooker or dryer is also steam heated.

**Potential Hazards.** The recognized hazards associated with cookers and dryers are the risk that employees could be:

1. Struck or caught by rotating agitator;
2. Engulfed in raw material or hot, recycled fat;

3. Burned by steam from leaks into the cooker/dryer steam jacket or the condenser duct system if steam valves are not properly closed and locked out;
4. Burned by contact with hot metal surfaces, such as the agitator shaft assembly, or inner shell of the cooker/dryer;
5. Heat stress caused by warm atmosphere inside cooker/dryer;
6. Slipping and falling on grease in the cooker/dryer;
7. Electrically shocked by faulty equipment taken into the cooker/dryer;
8. Burned or overcome by fire or products of combustion; or
9. Overcome by fumes generated by welding or cutting done on grease covered surfaces.

**Permits.** The supervisor in this case is always present at the cooker/dryer or other permit entry confined space when entry is made. The supervisor must follow the pre-entry isolation procedures described in the entry permit in preparing for entry, and ensure that the protective clothing, ventilating equipment and any other equipment required by the permit are at the entry site.

**Control of hazards.** Mechanical. Lock out main power switch to agitator motor at main power panel. Affix tag to the lock to inform others that a permit entry confined space entry is in progress.

**Engulfment.** Close all valves in the raw material blow line. Secure each valve in its closed position using chain and lock. Attach a tag to the valve and chain warning that a permit entry confined space entry is in progress. The same procedure shall be used for securing the fat recycle valve.

**Burns and heat stress.** Close steam supply valves to jacket and secure with chains and tags. Insert solid blank at flange in cooker vent line to condenser manifold duct system. Vent cooker/dryer by opening access door at discharge end and top center door to allow natural ventilation throughout the entry. If faster cooling is needed, use a portable ventilation fan to increase ventilation. Cooling water may be circulated through the jacket to reduce both outer and inner surface temperatures of cooker/dryers faster. Check air and inner surface temperatures in cooker/dryer to assure they are within acceptable limits before entering, or use proper protective clothing.

**Fire and fume hazards.** Careful site preparation, such as cleaning the area within 4 inches (10.16 cm) of all welding or torch cutting operations, and proper ventilation are the preferred controls. All welding and cutting operations shall be done in accordance with the requirements of 29 CFR Part 1910, Subpart Q, OSHA's welding standard. Proper ventilation may be achieved by local exhaust ventilation, or the use of portable ventilation fans, or a combination of the two practices.

**Electrical shock.** Electrical equipment used in cooker/dryers shall be in serviceable condition.

**Slips and falls.** Remove residual grease before entering cooker/dryer.

**Attendant.** The supervisor shall be the attendant for employees entering cooker/dryers.

**Permit.** The permit shall specify how isolation shall be done and any other preparations needed before making entry. This is especially important in parallel arrangements of cooker/dryers so that the entire operation need not be shut down to allow safe entry into one unit.

**Rescue.** When necessary, the attendant shall call the fire department as previously arranged.

#### Example 3.

**Workplace.** Workplaces where tank cars, trucks, and trailers, dry bulk tanks and trailers, railroad tank cars, and similar portable tanks are fabricated or serviced.

- A. **During fabrication.** These tanks and dry-bulk carriers are entered repeatedly throughout the fabrication process. These products are not configured identically, but the manufacturing processes by which they are made are very similar.

**Sources of hazards.** In addition to the mechanical hazards arising from the risks that an entrant would be injured due to contact with components of the tank or the tools being used, there is also the risk that a worker could be injured by breathing fumes from welding materials or mists or vapors from materials used to coat the tank interior. In addition, many of these vapors and mists are flammable, so the failure to properly ventilate a tank could lead to a fire or explosion.

**Control of hazards.**

**Welding.** Local exhaust ventilation shall be used to remove welding fumes once the tank or carrier is completed to the point that workers may enter and exit only through a manhole. (Follow the requirements of 29 CFR 1910, Subpart Q, OSHA's welding standard, at all times.) Welding gas tanks may never be brought into a tank or carrier that is a permit entry confined space.

**Application of interior coatings/linings.** Atmospheric hazards shall be controlled by forced air ventilation sufficient to keep the atmospheric concentration of flammable materials below 10% of the lower flammable limit (LFL) (or lower explosive limit (LEL), whichever term is used locally). The appropriate respirators are provided and shall be used in addition to providing forced ventilation if the forced ventilation does not maintain acceptable respiratory conditions.

**Permits.** Because of the repetitive nature of the entries in these operations, an "Area Entry Permit" will be issued for a 1 month period to cover those production areas where tanks are fabricated to the point that entry and exit are made using manholes.

**Authorization.** Only the area supervisor may authorize an employee to enter a tank within the permit area. The area supervisor must determine that conditions in the tank trailer, dry bulk trailer or truck, etc. meet permit requirements before authorizing entry.

**Attendant.** The area supervisor shall designate an employee to maintain communication by employer specified means with employees working in tanks to ensure their safety. The attendant may not enter any permit entry confined space to rescue an entrant or for any other reason, unless authorized by the rescue procedure and, and even then, only after calling the rescue team and being relieved by as attendant by another worker.

**Communications and observation.** Communications between attendant and entrant(s) shall be maintained throughout entry. Methods of communication that may be specified by the permit include voice, voice powered radio, tapping or rapping codes on tank walls, signalling tugs on a rope, and the attendant's observation that work activities such as chipping, grinding, welding, spraying, etc., which require deliberate operator control continue normally. These activities often generate so much noise that the necessary hearing protection makes communication by voice difficult.

**Rescue procedures.** Acceptable rescue procedures include entry by a team of employee-rescuers, use of public emergency services, and procedures for breaching the tank. The area permit specifies which procedures are available, but the area supervisor makes the final decision based on circumstances. (Certain injuries may make it necessary to breach the tank to remove a person rather than risk additional injury by removal through an existing manhole. However, the supervisor must ensure that no breaching procedure used for rescue would violate terms of the entry permit. For instance, if the tank must be breached by cutting with a torch, the tank surfaces to be cut must be free of volatile or combustible coatings within 4 inches (10.16 cm) of the cutting line and the atmosphere within the tank must be below the LFL.

**Retrieval line and harnesses.** The retrieval lines and harnesses generally required under this standard are usually impractical for use in tanks because the internal configuration of the tanks and their interior baffles and other structures would prevent rescuers from hauling out injured entrants. However, unless the rescue procedure calls for breaching the tank for rescue, the rescue team shall be trained in the use of retrieval lines and harnesses for removing injured employees through manholes.

**B. Repair or service of "used" tanks and bulk trailers.**

**Sources of hazards.** In addition to facing the potential hazards encountered in fabrication or manufacturing, tanks or trailers which have been in service may contain residues of dangerous materials, whether left over from the transportation of hazardous cargoes or generated by chemical or bacterial action on residues of non-hazardous cargoes.

**Control of atmospheric hazards.** A "used" tank shall be brought into areas where tank entry is authorized only after the tank has been emptied, cleansed (without employee entry) of any residues, and purged of any potential atmospheric hazards.

**Welding.** In addition to tank cleaning for control of atmospheric hazards, coating and surface materials shall be removed 4 inches (10.16 cm) or more from any surface area where welding or other torch work will be done and care taken that the atmosphere within the tank remains well below the LFL. (Follow the requirements of 29 CFR 1910, Subpart Q, OSHA's welding standard, at all times.)

**Permits.** An entry permit valid for up to 1 year shall be issued prior to authorization of entry into used tank trailers, dry bulk trailers or trucks. In addition to the pre-entry cleaning requirement, this permit shall require the employee safeguards specified for new tank fabrication or construction permit areas.

**Authorization.** Only the area supervisor may authorize an employee to enter a tank trailer, dry bulk trailer or truck within the permit area. The area supervisor must determine that the entry permit requirements have been met before authorizing entry.

**Appendix D to §1910.146  
Sample Permits**

Appendix D-1

Confined Space Entry Permit

Date and Time Issued: \_\_\_\_\_ Date and Time Expires: \_\_\_\_\_

Job site/Space I.D.: \_\_\_\_\_ Job Supervisor: \_\_\_\_\_

Equipment to be worked on: \_\_\_\_\_ Work to be performed: \_\_\_\_\_

Stand-by personnel: \_\_\_\_\_

1. Atmospheric Checks: Time \_\_\_\_\_  
 Oxygen \_\_\_\_\_%  
 Explosive \_\_\_\_\_% L.F.L.  
 Toxic \_\_\_\_\_PPM

2. Tester's signature: \_\_\_\_\_

3. Source isolation (No Entry):	N/A	Yes	No
Pumps or lines blinded, disconnected, or blocked	( )	( )	( )
	( )	( )	( )

4. Ventilation Modification:	N/A	Yes	No
Mechanical	( )	( )	( )
Natural Ventilation only	( )	( )	( )

5. Atmospheric check after isolation and Ventilation:  
 Oxygen \_\_\_\_\_% > 19.5 %  
 Explosive \_\_\_\_\_% L.F.L. < 10 %  
 Toxic \_\_\_\_\_PPM < 10 PPM H<sub>2</sub>S  
 Time \_\_\_\_\_  
 Testers signature: \_\_\_\_\_

6. Communication procedures: \_\_\_\_\_

7. Rescue procedures: \_\_\_\_\_

8. Entry, standby, and back up persons:	Yes	No
Successfully completed required training?	( )	( )
Is it current?	( )	( )

9. Equipment:	N/A	Yes	No
Direct reading gas monitor - tested	( )	( )	( )
Safety harnesses and lifelines for entry and standby persons	( )	( )	( )
Hoisting equipment	( )	( )	( )
Powered communications	( )	( )	( )

SCBAs for entry and standby persons	( )	( )	( )
Protective Clothing	( )	( )	( )
All electric equipment listed			
Class I, Division I, Group D			
and Non-sparking tools	( )	( )	( )

10. Periodic atmospheric tests:

Oxygen ___%	Time ___	Oxygen ___%	Time ___
Oxygen ___%	Time ___	Oxygen ___%	Time ___
Explosive ___%	Time ___	Explosive ___%	Time ___
Explosive ___%	Time ___	Explosive ___%	Time ___
Toxic ___%	Time ___	Toxic ___%	Time ___
Toxic ___%	Time ___	Toxic ___%	Time ___

We have reviewed the work authorized by this permit and the information contained here-in. Written instructions and safety procedures have been received and are understood. Entry cannot be approved if any squares are marked in the "No" column. This permit is not valid unless all appropriate items are completed.

Permit Prepared By: (Supervisor)  
 Approved By: (Unit Supervisor)  
 Reviewed By (Cs Operations Personnel):

_____	_____
(printed name)	(signature)

This permit to be kept at job site. Return job site copy to Safety Office following job completion.

Copies: White Original (Safety Office)  
 Yellow (Unit Supervisor)  
 Hard (Job site)

Appendix D-2

ENTRY PERMIT

PERMIT VALID FOR 8 HOURS ONLY. ALL COPIES OF PERMIT WILL REMAIN AT JOB SITE UNTIL JOB IS COMPLETED

DATE: - - SITE LOCATION and DESCRIPTION  
 PURPOSE OF ENTRY  
 SUPERVISOR(S) in charge of crews      Type of Crew    Phone #

\_\_\_\_\_ COMMUNICATION PROCEDURES

RESCUE PROCEDURES (PHONE NUMBERS AT BOTTOM)

**\*BOLD DENOTES MINIMUM REQUIREMENTS TO BE COMPLETED AND REVIEWED PRIOR TO ENTRY\***

REQUIREMENTS COMPLETED	DATE	TIME
Lock Out/De-energize/Try-out	_____	_____
Line(s) Broken-Capped-Blanked	_____	_____
Purge-Flush and Vent	_____	_____
Ventilation	_____	_____

Secure Area (Post and Flag) \_\_\_\_\_  
 Breathing Apparatus \_\_\_\_\_  
 Resuscitator - Inhalator \_\_\_\_\_  
 Standby Safety Personnel \_\_\_\_\_  
 Full Body Harness w/ "D" ring \_\_\_\_\_  
 Emergency Escape Retrieval Equip \_\_\_\_\_  
 Lifelines \_\_\_\_\_  
 Fire Extinguishers \_\_\_\_\_  
 Lighting (Explosive Proof) \_\_\_\_\_  
 Protective Clothing \_\_\_\_\_  
 Respirator(s) (Air Purifying) \_\_\_\_\_  
 Burning and Welding Permit \_\_\_\_\_  
 Note: Items that do not apply enter N/A in the blank.

**\*\*RECORD CONTINUOUS MONITORING RESULTS EVERY 2 HOURS**

CONTINUOUS MONITORING**	Permissible								
TEST(S) TO BE TAKEN	Entry Level								
PERCENT OF OXYGEN	19.5% to 23.5%								
LOWER FLAMMABLE LIMIT	Under 10%	-	-	-	-	-	-	-	-
CARBON MONOXIDE	+35 PPM	-	-	-	-	-	-	-	-
Aromatic Hydrocarbon	+ 1 PPM * 5PPM	-	-	-	-	-	-	-	-
Hydrogen Cyanide	(Skin) * 4PPM								
Hydrogen Sulfide	+10 PPM *15PPM	-	-	-	-	-	-	-	-
Sulfur Dioxide	+ 2 PPM * 5PPM	-	-	-	-	-	-	-	-
Ammonia	*35PPM	-	-	-	-	-	-	-	-

\* Short-term exposure limit: Employee can work in the area up to 15 minutes.  
 + 8 hr. Time Weighted Avg.: Employee can work in area 8 hrs (longer with appropriate respiratory protection).

REMARKS:

GAS TESTER NAME & CHECK #	INSTRUMENT(S) USED	MODEL &/OR TYPE	SERIAL &/OR UNIT #
_____	_____	_____	_____
_____	_____	_____	_____

**SAFETY STANDBY PERSON IS REQUIRED FOR ALL CONFINED SPACE WORK**

SAFETY STANDBY PERSON(S)	CHECK #	CONFINED SPACE ENTRANT(S)	CHECK #	CONFINED SPACE ENTRANT(S)
_____	_____	_____	_____	_____
_____	_____	_____	_____	_____

SUPERVISOR AUTHORIZING - ALL CONDITIONS SATISFIED  
 DEPARTMENT/PHONE  
 AMBULANCE 2800 FIRE 2900 Safety 4901 Gas Coordinator 4529/5387



**APPENDIX E TO §1910.146  
SEWER SYSTEM ENTRY**

Sewer entry differs in three vital respects from other permit entries; first, there rarely exists any way to completely isolate the space (a section of a continuous system) to be entered; second, because isolation is not complete, the atmosphere may suddenly and unpredictably become lethally hazardous (toxic, flammable or explosive) from causes beyond the control of the entrant or employer, and third, experienced sewer workers are especially knowledgeable in entry and work in their permit spaces because of their frequent entries. Unlike other employments where permit space entry is a rare and exceptional event, sewer workers' usual work environment is a permit space.

- (1) Adherence to procedure. The employer should designate as entrants only employees who are thoroughly trained in the employer's sewer entry procedures and who demonstrate that they follow these entry procedures exactly as prescribed when performing sewer entries.
- (2) Atmospheric monitoring. Entrants should be trained in the use of, and be equipped with, atmospheric monitoring equipment which sounds an audible alarm, in addition to its visual readout, whenever one of the following conditions are encountered: Oxygen concentration less than 19.5 percent; flammable gas or vapor at 10 percent or more of the lower flammable limit (LFL); or hydrogen sulfide or carbon monoxide at or above 10 ppm or 35 ppm, respectively, measured as an 8-hour time-weighted average. Atmospheric monitoring equipment needs to be calibrated according to the manufacturer's instructions. The oxygen sensor/broad range sensor is best suited for initial use in situations where the actual or potential contaminants have not been identified, because broad range sensors, unlike substance-specific sensors, enable employers to obtain an overall reading of the hydrocarbons (flammables) present in the space. However, such sensors only indicate that a hazardous threshold of a class of chemicals has been exceeded. They do not measure the levels of contamination of specific substances. Therefore, substance-specific devices, which measure the actual levels of specific substances, are best suited for use where actual and potential contaminants have been identified. The measurements obtained with substance-specific devices are of vital importance to the employer when decisions are made concerning the measures necessary to protect entrants (such as ventilation or personal protective equipment) and the setting and attainment of appropriate entry conditions. However, the sewer environment may suddenly and unpredictably change, and the substance-specific devices may not detect the potentially lethal atmospheric hazards which may enter the sewer environment.

Although OSHA considers the information and guidance provided above to be appropriate and useful in most sewer entry situations, the Agency emphasizes that each employer must consider the unique circumstances, including the predictability of the atmosphere, of the sewer permit spaces in the employer's workplace in preparing for entry. Only the employer can decide, based upon his or her knowledge of, and experience with permit spaces in sewer systems, what the best type of testing instrument may be for any specific entry operation.

The selected testing instrument should be carried and used by the entrant in sewer line work to monitor the atmosphere in the entrant's environment, and in advance of the entrant's direction of movement, to warn the entrant of any deterioration in atmospheric conditions. Where several entrants are working together in the same immediate location, one instrument, used by the lead entrant, is acceptable.

- (3) Surge flow and flooding. Sewer crews should develop and maintain liaison, to the extent possible, with the local weather bureau and fire and emergency services in their area so that sewer work may be delayed or interrupted and entrants withdrawn whenever sewer lines might be suddenly flooded by rain or fire suppression activities, or whenever flammable or other hazardous materials are released into sewers during emergencies by industrial or transportation accidents.
- (4) Special Equipment. Entry into large bore sewers may require the use of special equipment. Such equipment might include such items as atmosphere monitoring devices with automatic audible alarms, escape self-contained breathing apparatus (ESCBA) with at least 10 minute air supply (or other NIOSH approved self-rescuer), and waterproof flashlights, and may also include boats and rafts, radios and rope stand-offs for pulling around bends and corners as needed.

**APPENDIX F TO §1910.146**  
**RESCUE TEAM OR RESCUE SERVICE EVALUATION CRITERIA (NON-MANDATORY)**

- (1) This appendix provides guidance to employers in choosing an appropriate rescue service. It contains criteria that may be used to evaluate the capabilities both of prospective and current rescue teams. Before a rescue team can be trained or chosen, however, a satisfactory permit program, including an analysis of all permit-required confined spaces to identify all potential hazards in those spaces, must be completed. OSHA believes that compliance with all the provisions of §1910.146 will enable employers to conduct permit space operations without recourse to rescue services in nearly all cases. However, experience indicates that circumstances will arise where entrants will need to be rescued from permit spaces. It is therefore important for employers to select rescue services or teams, either on-site or off-site, that are equipped and capable of minimizing harm to both entrants and rescuers if the need arises.
- (2) For all rescue teams or services, the employer's evaluation should consist of two components: an initial evaluation, in which employers decide whether a potential rescue service or team is adequately trained and equipped to perform permit space rescues of the kind needed at the facility and whether such rescuers can respond in a timely manner, and a performance evaluation, in which employers measure the performance of the team or service during an actual or practice rescue. For example, based on the initial evaluation, an employer may determine that maintaining an on-site rescue team will be more expensive than obtaining the services of an off-site team, without being significantly more effective, and decide to hire a rescue service. During a performance evaluation, the employer could decide, after observing the rescue service perform a practice rescue, that the service's training or preparedness was not adequate to effect a timely or effective rescue at his or her facility and decide to select another rescue service, or to form an internal rescue team.

**A. Initial Evaluation**

- I. The employer should meet with the prospective rescue service to facilitate the evaluations required by §1910.146(k)(1)(i) and §1910.146(k)(1)(ii). At a minimum, if an off-site rescue service is being considered, the employer must contact the service to plan and coordinate the evaluations required by the standard. Merely posting the service's number or planning to rely on the 911 emergency phone number to obtain these services at the time of a permit space emergency would not comply with paragraph (k)(1) of the standard.
- II. The capabilities required of a rescue service vary with the type of permit spaces from which rescue may be necessary and the hazards likely to be encountered in those spaces. Answering the questions below will assist employers in determining whether the rescue service is capable of performing rescues in the permit spaces present at the employer's workplace.
  1. What are the needs of the employer with regard to response time (time for the rescue service to receive notification, arrive at the scene, and set up and be ready for entry)? For example, if entry is to be made into an IDLH atmosphere, or into a space that can quickly develop an IDLH atmosphere (if ventilation fails or for other reasons), the rescue team or service would need to be standing by at the permit space. On the other hand, if the danger to entrants is restricted to mechanical hazards that would cause injuries (e.g., broken bones, abrasions) a response time of 10 or 15 minutes might be adequate.
  2. How quickly can the rescue team or service get from its location to the permit spaces from which rescue may be necessary? Relevant factors to consider would include: the location of the rescue team or service relative to the employer's workplace, the quality of roads and highways to be traveled, potential bottlenecks or traffic congestion that might be encountered in transit, the reliability of the rescuer's vehicles, and the training and skill of its drivers.
  3. What is the availability of the rescue service? Is it unavailable at certain times of the day or in certain situations? What is the likelihood that key personnel of the rescue service might be unavailable at times? If the rescue service becomes unavailable while an entry is underway, does it have the capability of notifying the employer so that the employer can instruct the attendant to abort the entry immediately?

4. Does the rescue service meet all the requirements of paragraph (k)(2) of the standard? If not, has it developed a plan that will enable it to meet those requirements in the future? If so, how soon can the plan be implemented?
5. For off-site services, is the service willing to perform rescues at the employer's workplace? (An employer may not rely on a rescuer who declines, for whatever reason, to provide rescue services.)
6. Is an adequate method for communications between the attendant, employer and prospective rescuer available so that a rescue request can be transmitted to the rescuer without delay? How soon after notification can a prospective rescuer dispatch a rescue team to the entry site?
7. For rescues into spaces that may pose significant atmospheric hazards and from which rescue entry, patient packaging and retrieval cannot be safely accomplished in a relatively short time (15-20 minutes), employers should consider using airline respirators (with escape bottles) for the rescuers and to supply rescue air to the patient. If the employer decides to use SCBA, does the prospective rescue service have an ample supply of replacement cylinders and procedures for rescuers to enter and exit (or be retrieved) well within the SCBA's air supply limits?
8. If the space has a vertical entry over 5 feet in depth, can the prospective rescue service properly perform entry rescues? Does the service have the technical knowledge and equipment to perform rope work or elevated rescue, if needed?
9. Does the rescue service have the necessary skills in medical evaluation, patient packaging and emergency response?
10. Does the rescue service have the necessary equipment to perform rescues, or must the equipment be provided by the employer or another source?

### **B. Performance Evaluation**

Rescue services are required by paragraph (k)(2)(iv) of the standard to practice rescues at least once every 12 months, provided that the team or service has not successfully performed a permit space rescue within that time. As part of each practice session, the service should perform a critique of the practice rescue, or have another qualified party perform the critique, so that deficiencies in procedures, equipment, training, or number of personnel can be identified and corrected. The results of the critique, and the corrections made to respond to the deficiencies identified, should be given to the employer to enable it to determine whether the rescue service can quickly be upgraded to meet the employer's rescue needs or whether another service must be selected. The following questions will assist employers and rescue teams and services evaluate their performance.

1. Have all members of the service been trained as permit space entrants, at a minimum, including training in the potential hazards of all permit spaces, or of representative permit spaces, from which rescue may be needed? Can team members recognize the signs, symptoms, and consequences of exposure to any hazardous atmospheres that may be present in those permit spaces?
2. Is every team member provided with, and properly trained in, the use and need for PPE, such as SCBA or fall arrest equipment, which may be required to perform permit space rescues in the facility? Is every team member properly trained to perform his or her functions and make rescues, and to use any rescue equipment, such as ropes and backboards, that may be needed in a rescue attempt?
3. Are team members trained in the first aid and medical skills needed to treat victims overcome or injured by the types of hazards that may be encountered in the permit spaces at the facility?
4. Do all team members perform their functions safely and efficiently? Do rescue service personnel focus on their own safety before considering the safety of the victim?
5. If necessary, can the rescue service properly test the atmosphere to determine if it is IDLH?
6. Can the rescue personnel identify information pertinent to the rescue from entry permits, hot work permits, and MSDSs?
7. Has the rescue service been informed of any hazards to personnel that may arise from outside the space, such as those that may be caused by future work near the space?
8. If necessary, can the rescue service properly package and retrieve victims from a permit space that has a limited size opening (less than 24 inches (60.9 cm) in diameter), limited internal space, or internal obstacles or hazards?
9. If necessary, can the rescue service safely perform an elevated (high angle) rescue?

10. Does the rescue service have a plan for each of the kinds of permit space rescue operations at the facility? Is the plan adequate for all types of rescue operations that may be needed at the facility? Teams may practice in representative spaces, or in spaces that are "worst-case" or most restrictive with respect to internal configuration, elevation, and portal size. The following characteristics of a practice space should be considered when deciding whether a space is truly representative of an actual permit space:
- (1) Internal configuration.
    - (a) Open -- there are no obstacles, barriers, or obstructions within the space. One example is a water tank.
    - (b) Obstructed -- the permit space contains some type of obstruction that a rescuer would need to maneuver around. An example would be a baffle or mixing blade. Large equipment, such as a ladder or scaffold, brought into a space for work purposes would be considered an obstruction if the positioning or size of the equipment would make rescue more difficult.
  - (2) Elevation.
    - (a) Elevated -- a permit space where the entrance portal or opening is above grade by 4 feet or more. This type of space usually requires knowledge of high angle rescue procedures because of the difficulty in packaging and transporting a patient to the ground from the portal.
    - (b) Non-elevated -- a permit space with the entrance portal located less than 4 feet above grade. This type of space will allow the rescue team to transport an injured employee normally.
  - (3) Portal size.
    - (a) Restricted -- A portal of 24 inches or less in the least dimension. Portals of this size are too small to allow a rescuer to simply enter the space while using SCBA. The portal size is also too small to allow normal spinal immobilization of an injured employee.
    - (b) Unrestricted -- A portal of greater than 24 inches in the least dimension. These portals allow relatively free movement into and out of the permit space.
  - (4) Space access.
    - (a) Horizontal -- The portal is located on the side of the permit space. Use of retrieval lines could be difficult.
    - (b) Vertical -- The portal is located on the top of the permit space, so that rescuers must climb down, or the bottom of the permit space, so that rescuers must climb up to enter the space. Vertical portals may require knowledge of rope techniques, or special patient packaging to safely retrieve a downed entrant.

**§1910.147 The control of hazardous energy (lockout/tagout).**

- (a) Scope, application and purpose
  - (1) Scope.
    - (i) This standard covers the servicing and maintenance of machines and equipment in which the unexpected energization or start up of the machines or equipment, or release of stored energy could cause injury to employees. This standard establishes minimum performance requirements for the control of such hazardous energy.
    - (ii) This standard does not cover the following:
      - (A) Construction, agriculture and maritime employment;
      - (B) Installations under the exclusive control of electric utilities for the purpose of power generation, transmission and distribution, including related equipment for communication or metering; and
      - (C) Exposure to electrical hazards from work on, near, or with conductors or equipment in electric utilization installations, which is covered by subpart S of this part; and
      - (D) Oil and gas well drilling and servicing.
  - (2) Application.
    - (i) This standard applies to the control of energy during servicing and/or maintenance of machines and equipment.
    - (ii) Normal production operations are not covered by this standard (See subpart O of this part). Servicing and/or maintenance which takes place during normal production operations is covered by this standard only if:

- (A) An employee is required to remove or bypass a guard or other safety device; or
- (B) An employee is required to place any part of his or her body into an area on a machine or piece of equipment where work is actually performed upon the material being processed (point of operation) or where an associated danger zone exists during a machine operating cycle.

**Note:** Exception to paragraph (a)(2)(ii): Minor tool changes and adjustments, and other minor servicing activities, which take place during normal production operations, are not covered by this standard if they are routine, repetitive, and integral to the use of the equipment for production, provided that the work is performed using alternative measures which provide effective protection (See subpart O of this part).

- (iii) This standard does not apply to the following.
  - (A) Work on cord and plug connected electric equipment for which exposure to the hazards of unexpected energization or start up of the equipment is controlled by the unplugging of the equipment from the energy source and by the plug being under the exclusive control of the employee performing the servicing or maintenance.
  - (B) Hot tap operations involving transmission and distribution systems for substances such as gas, steam, water or petroleum products when they are performed on pressurized pipelines, provided that the employer demonstrates that (1) continuity of service is essential; (2) shutdown of the system is impractical; and (3) documented procedures are followed, and special equipment is used which will provide proven effective protection for employees.

(3) Purpose.

- (i) This section requires employers to establish a program and utilize procedures for affixing appropriate lockout devices or tagout devices to energy isolating devices, and to otherwise disable machines or equipment to prevent unexpected energization, start-up or release of stored energy in order to prevent injury to employees.
- (ii) When other standards in this part require the use of lockout or tagout, they shall be used and supplemented by the procedural and training requirements of this section.

(b) Definitions applicable to this section.

**Affected employee.** An employee whose job requires him/her to operate or use a machine or equipment on which servicing or maintenance is being performed under lockout or tagout, or whose job requires him/her to work in an area in which such servicing or maintenance is being performed.

**Authorized employee.** A person who locks out or tags out machines or equipment in order to perform servicing or maintenance on that machine or equipment. An affected employee becomes an authorized employee when that employee's duties include performing servicing or maintenance covered under this section.

**Capable of being locked out.** An energy isolating device is capable of being locked out if it has a hasp or other means of attachment to which, or through which, a lock can be affixed, or it has a locking mechanism built into it. Other energy isolating devices are capable of being locked out, if lockout can be achieved without the need to dismantle, rebuild, or replace the energy isolating device or permanently alter its energy control capability.

**Energized.** Connected to an energy source or containing residual or stored energy.

**Energy isolating device.** A mechanical device that physically prevents the transmission or release of energy, including but not limited to the following: A manually operated electrical circuit breaker; a disconnect switch; a manually operated switch by which the conductors of a circuit can be disconnected from all ungrounded supply conductors, and, in addition, no pole can be operated independently; a line valve; a block; and any similar device used to block or isolate energy. Push buttons, selector switches and other control circuit type devices are not energy isolating devices.

**Energy source.** Any source of electrical, mechanical, hydraulic, pneumatic, chemical, thermal, or other energy.

**Hot tap.** A procedure used in the repair, maintenance and services activities which involves welding on a piece of equipment (pipelines, vessels or tanks) under pressure, in order to install connections or appurtenances. It is commonly used to replace or add sections of pipeline without the interruption of service for air, gas, water, steam, and petrochemical distribution systems.

**Lockout.** The placement of a lockout device on an energy isolating device, in accordance with an established procedure, ensuring that the energy isolating device and the equipment being controlled cannot be operated until the lockout device is removed.

**Lockout device.** A device that utilizes a positive means such as a lock, either key or combination type, to hold an energy isolating device in the safe position and prevent the energizing of a machine or equipment. Included are blank flanges and bolted slip blinds.

**Normal production operations.** The utilization of a machine or equipment to perform its intended production function.

**Servicing and/or maintenance.** Workplace activities such as constructing, installing, setting up, adjusting, inspecting, modifying, and maintaining and/or servicing machines or equipment. These activities include lubrication, cleaning or unjamming of machines or equipment and making adjustments or tool changes, where the employee may be exposed to the unexpected energization or startup of the equipment or release of hazardous energy.

**Setting up.** Any work performed to prepare a machine or equipment to perform its normal production operation.

**Tagout.** The placement of a tagout device on an energy isolating device, in accordance with an established procedure, to indicate that the energy isolating device and the equipment being controlled may not be operated until the tagout device is removed.

**Tagout device.** A prominent warning device, such as a tag and a means of attachment, which can be securely fastened to an energy isolating device in accordance with an established procedure, to indicate that the energy isolating device and the equipment being controlled may not be operated until the tagout device is removed.

**(c) General**

- (1) Energy control program. The employer shall establish a program consisting of energy control procedures, employee training and periodic inspections to ensure that before any employee performs any servicing or maintenance on a machine or equipment where the unexpected energizing, start up or release of stored energy could occur and cause injury, the machine or equipment shall be isolated from the energy source, and rendered inoperative.
- (2) Lockout/tagout.
  - (i) If an energy isolating device is not capable of being locked out, the employer's energy control program under paragraph (c)(1) of this section shall utilize a tagout system.
  - (ii) If an energy isolating device is capable of being locked out, the employer's energy control program under paragraph (c)(1) of this section shall utilize lockout, unless the employer can demonstrate that the utilization of a tagout system will provide full employee protection as set forth in paragraph (c)(3) of this section.
  - (iii) After January 2, 1990, whenever replacement or major repair, renovation or modification of a machine or equipment is performed, and whenever new machines or equipment are installed, energy isolating devices for such machine or equipment shall be designed to accept a lockout device.
- (3) Full employee protection.
  - (i) When a tagout device is used on an energy isolating device which is capable of being locked out, the tagout device shall be attached at the same location that the lockout device would have been attached, and the employer shall demonstrate that the tagout program will provide a level of safety equivalent to that obtained by using a lockout program.
  - (ii) In demonstrating that a level of safety is achieved in the tagout program which is equivalent to the level of safety obtained by using a lockout program, the employer shall demonstrate full compliance with all tagout-related provisions of this standard together with such additional elements as are necessary to provide the equivalent safety available from the use of a lockout device. Additional means to be considered as part of the demonstration of full employee protection shall include the implementation of additional safety measures such as the removal of an isolating circuit element, blocking of a controlling switch, opening of an extra disconnecting device, or the removal of a valve handle to reduce the likelihood of inadvertent energization.
- (4) Energy control procedure.
  - (i) Procedures shall be developed, documented and utilized for the control of potentially hazardous energy when employees are engaged in the activities covered by this section.

**Note:** Exception: The employer need not document the required procedure for a particular machine or equipment, when all of the following elements exist: (1) The machine or equipment has no potential for stored or residual energy or reaccumulation of stored energy after shut down which could endanger employees; (2) the machine or equipment has a single energy source which can be readily identified and isolated; (3) the isolation and locking out of that energy source will completely deenergize and deactivate the machine or equipment; (4) the machine or equipment is isolated from that energy source and locked out during servicing or maintenance; (5) a single lockout device will achieve a locked-out condition; (6) the lockout device is under the exclusive control of the authorized employee performing the servicing or maintenance; (7) the servicing or maintenance does not create hazards for other employees; and (8) the employer, in utilizing this exception, has had no accidents involving the unexpected activation or reenergization of the machine or equipment during servicing or maintenance.

- (ii) The procedures shall clearly and specifically outline the scope, purpose, authorization, rules, and techniques to be utilized for the control of hazardous energy, and the means to enforce compliance including, but not limited to, the following:
  - (A) A specific statement of the intended use of the procedure;
  - (B) Specific procedural steps for shutting down, isolating, blocking and securing machines or equipment to control hazardous energy;
  - (C) Specific procedural steps for the placement, removal and transfer of lockout devices or tagout devices and the responsibility for them; and
  - (D) Specific requirements for testing a machine or equipment to determine and verify the effectiveness of lockout devices, tagout devices, and other energy control measures.
- (5) Protective materials and hardware.
  - (i) Locks, tags, chains, wedges, key blocks, adapter pins, self-locking fasteners, or other hardware shall be provided by the employer for isolating, securing or blocking of machines or equipment from energy sources.
  - (ii) Lockout devices and tagout devices shall be singularly identified; shall be the only device(s) used for controlling energy; shall not be used for other purposes; and shall meet the following requirements:
    - (A) Durable.
      - (1) Lockout and tagout devices shall be capable of withstanding the environment to which they are exposed for the maximum period of time that exposure is expected.
      - (2) Tagout devices shall be constructed and printed so that exposure to weather conditions or wet and damp locations will not cause the tag to deteriorate or the message on the tag to become illegible.
      - (3) Tags shall not deteriorate when used in corrosive environments such as areas where acid and alkali chemicals are handled and stored.
    - (B) Standardized. Lockout and tagout devices shall be standardized within the facility in at least one of the following criteria: Color; shape; or size; and additionally, in the case of tagout devices, print and format shall be standardized.
    - (C) Substantial
      - (1) Lockout devices. Lockout devices shall be substantial enough to prevent removal without the use of excessive force or unusual techniques, such as with the use of bolt cutters or other metal cutting tools.
      - (2) Tagout devices. Tagout devices, including and their means of attachment, shall be substantial enough to prevent inadvertent or accidental removal. Tagout device attachment means shall be of a non-reusable type, attachable by hand, self-locking, and non-releasable with a minimum unlocking strength of no less than 50 pounds and having the general design and basic characteristics of being at least equivalent to a one-piece, all-environment-tolerant nylon cable tie.
    - (D) Identifiable. Lockout devices and tagout devices shall indicate the identify of the employee applying the device(s).

- (iii) Tagout devices shall warn against hazardous conditions if the machine or equipment is energized and shall include a legend such as the following: Do Not Start, Do Not Open, Do Not Close, Do Not Energize, Do Not Operate.
- (6) Periodic inspection.
  - (i) The employer shall conduct a periodic inspection of the energy control procedure at least annually to ensure that the procedure and the requirements of this standard are being followed.
    - (A) The periodic inspection shall be performed by an authorized employee other than the one(s) utilizing the energy control procedure being inspected.
    - (B) The periodic inspection shall be conducted to correct any deviations or inadequacies identified.
    - (C) Where lockout is used for energy control, the periodic inspection shall include a review, between the inspector and each authorized employee, of that employee's responsibilities under the energy control procedure being inspected.
    - (D) Where tagout is used for energy control, the periodic inspection shall include a review, between the inspector and each authorized and affected employee, of that employee's responsibilities under the energy control procedure being inspected, and the elements set forth in paragraph (c)(7)(ii) of this section.
  - (ii) The employer shall certify that the periodic inspections have been performed. The certification shall identify the machine or equipment on which the energy control procedure was being utilized, the date of the inspection, the employees included in the inspection, and the person performing the inspection.
- (7) Training and communication.
  - (i) The employer shall provide training to ensure that the purpose and function of the energy control program are understood by employees and that the knowledge and skills required for the safe application, usage, and removal of the energy controls are acquired by employees. The training shall include the following:
    - (A) Each authorized employee shall receive training in the recognition of applicable hazardous energy sources, the type and magnitude of the energy available in the workplace, and the methods and means necessary for energy isolation and control.
    - (B) Each affected employee shall be instructed in the purpose and use of the energy control procedure.
    - (C) All other employees whose work operations are or may be in an area where energy control procedures may be utilized, shall be instructed about the procedure, and about the prohibition relating to attempts to restart or reenergize machines or equipment which are locked out or tagged out.
  - (ii) When tagout systems are used, employees shall also be trained in the following limitations of tags:
    - (A) Tags are essentially warning devices affixed to energy isolating devices, and do not provide the physical restraint on those devices that is provided by a lock.
    - (B) When a tag is attached to an energy isolating means, it is not to be removed without authorization of the authorized person responsible for it, and it is never to be bypassed, ignored, or otherwise defeated.
    - (C) Tags must be legible and understandable by all authorized employees, affected employees, and all other employees whose work operations are or may be in the area, in order to be effective.
    - (D) Tags and their means of attachment must be made of materials which will withstand the environmental conditions encountered in the workplace.
    - (E) Tags may evoke a false sense of security, and their meaning needs to be understood as part of the overall energy control program.
    - (F) Tags must be securely attached to energy isolating devices so that they cannot be inadvertently or accidentally detached during use.
  - (iii) Employee retraining.
    - (A) Retraining shall be provided for all authorized and affected employees whenever there is a change in their job assignments, a change in machines, equipment or processes



- that present a new hazard, or when there is a change in the energy control procedures.
- (B) Additional retraining shall also be conducted whenever a periodic inspection under paragraph (c)(6) of this section reveals, or whenever the employer has reason to believe, that there are deviations from or inadequacies in the employee's knowledge or use of the energy control procedures.
  - (C) The retraining shall reestablish employee proficiency and introduce new or revised control methods and procedures, as necessary.
- (iv) The employer shall certify that employee training has been accomplished and is being kept up to date. The certification shall contain each employee's name and dates of training.
- (8) Energy isolation. Lockout or tagout shall be performed only by the authorized employees who are performing the servicing or maintenance.
  - (9) Notification of employees. Affected employees shall be notified by the employer or authorized employee of the application and removal of lockout devices or tagout devices. Notification shall be given before the controls are applied, and after they are removed from the machine or equipment.
- (d) Application of control. The established procedures for the application of energy control (the lockout or tagout procedures) shall cover the following elements and actions and shall be done in the following sequence:
- (1) Preparation for shutdown. Before an authorized or affected employee turns off a machine or equipment, the authorized employee shall have knowledge of the type and magnitude of the energy, the hazards of the energy to be controlled, and the method or means to control the energy.
  - (2) Machine or equipment shutdown. The machine or equipment shall be turned off or shut down using the procedures established for the machine or equipment. An orderly shutdown must be utilized to avoid any additional or increased hazard(s) to employees as a result of the equipment stoppage.
  - (3) Machine or equipment isolation. All energy isolating devices that are needed to control the energy to the machine or equipment shall be physically located and operated in such a manner as to isolate the machine or equipment from the energy source(s).
  - (4) Lockout or tagout device application.
    - (i) Lockout or tagout devices shall be affixed to each energy isolating device by authorized employees.
    - (ii) Lockout devices, where used, shall be affixed in a manner to that will hold the energy isolating devices in a "safe" or "off" position.
    - (iii) Tagout devices, where used, shall be affixed in such a manner as will clearly indicate that the operation or movement of energy isolating devices from the "safe" or "off" position is prohibited.
      - (A) Where tagout devices are used with energy isolating devices designed with the capability of being locked, the tag attachment shall be fastened at the same point at which the lock would have been attached.
      - (B) Where a tag cannot be affixed directly to the energy isolating device, the tag shall be located as close as safely possible to the device, in a position that will be immediately obvious to anyone attempting to operate the device.
  - (5) Stored energy.
    - (i) Following the application of lockout or tagout devices to energy isolating devices, all potentially hazardous stored or residual energy shall be relieved, disconnected, restrained, and otherwise rendered safe.
    - (ii) If there is a possibility of reaccumulation of stored energy to a hazardous level, verification of isolation shall be continued until the servicing or maintenance is completed, or until the possibility of such accumulation no longer exists.
  - (6) Verification of isolation. Prior to starting work on machines or equipment that have been locked out or tagged out, the authorized employee shall verify that isolation and deenergization of the machine or equipment have been accomplished.

- (e) Release from lockout or tagout. Before lockout or tagout devices are removed and energy is restored to the machine or equipment, procedures shall be followed and actions taken by the authorized employee(s) to ensure the following:
- (1) The machine or equipment. The work area shall be inspected to ensure that nonessential items have been removed and to ensure that machine or equipment components are operationally intact.
  - (2) Employees.
    - (i) The work area shall be checked to ensure that all employees have been safely positioned or removed.
    - (ii) After lockout or tagout devices have been removed and before a machine or equipment is started, affected employees shall be notified that the lockout or tagout device(s) have been removed.
  - (3) Lockout or tagout devices removal. Each lockout or tagout device shall be removed from each energy isolating device by the employee who applied the device. Exception to paragraph (e)(3): When the authorized employee who applied the lockout or tagout device is not available to remove it, that device may be removed under the direction of the employer, provided that specific procedures and training for such removal have been developed, documented and incorporated into the employer's energy control program. The employer shall demonstrate that the specific procedure provides equivalent safety to the removal of the device by the authorized employee who applied it. The specific procedure shall include at least the following elements:
    - (i) Verification by the employer that the authorized employee who applied the device is not at the facility;
    - (ii) Making all reasonable efforts to contact the authorized employee to inform him/her that his/her lockout or tagout device has been removed; and
    - (iii) Ensuring that the authorized employee has this knowledge before he/she resumes work at that facility.
- (f) Additional requirements
- (1) Testing or positioning of machines, equipment or components thereof. In situations in which lockout or tagout devices must be temporarily removed from the energy isolating device and the machine or equipment energized to test or position the machine, equipment or component thereof, the following sequence of actions shall be followed:
    - (i) Clear the machine or equipment of tools and materials in accordance with paragraph (e)(1) of this section;
    - (ii) Remove employees from the machine or equipment area in accordance with paragraph (e)(2) of this section;
    - (iii) Remove the lockout or tagout devices as specified in paragraph (e)(3) of this section;
    - (iv) Energize and proceed with testing or positioning;
    - (v) Deenergize all systems and reapply energy control measures in accordance with paragraph (d) of this section to continue the servicing and/or maintenance.
  - (2) Outside personnel (contractors, etc.).
    - (i) Whenever outside servicing personnel are to be engaged in activities covered by the scope and application of this standard, the on-site employer and the outside employer shall inform each other of their respective lockout or tagout procedures.
    - (ii) The on-site employer shall ensure that his/her employees understand and comply with the restrictions and prohibitions of the outside employer's energy control program.
  - (3) Group lockout or tagout.
    - (i) When servicing and/or maintenance is performed by a crew, craft, department or other group, they shall utilize a procedure which affords the employees a level of protection equivalent to that provided by the implementation of a personal lockout or tagout device.
    - (ii) Group lockout or tagout devices shall be used in accordance with the procedures required by paragraph (c)(4) of this section including, but not necessarily limited to, the following specific requirements:
      - (A) Primary responsibility is vested in an authorized employee for a set number of employees working under the protection of a group lockout or tagout device (such as an operations lock);

- (B) Provision for the authorized employee to ascertain the exposure status of individual group members with regard to the lockout or tagout of the machine or equipment and
  - (C) When more than one crew, craft, department, etc. is involved, assignment of overall job-associated lockout or tagout control responsibility to an authorized employee designated to coordinate affected work forces and ensure continuity of protection; and
  - (D) Each authorized employee shall affix a personal lockout or tagout device to the group lockout device, group lockbox, or comparable mechanism when he or she begins work, and shall remove those devices when he or she stops working on the machine or equipment being serviced or maintained.
- (4) Shift or personnel changes. Specific procedures shall be utilized during shift or personnel changes to ensure the continuity of lockout or tagout protection, including provision for the orderly transfer of lockout or tagout device protection between off-going and oncoming employees, to minimize exposure to hazards from the unexpected energization or start-up of the machine or equipment, or the release of stored energy.

**Note:** The following Appendix to §1910.147 serves as a non-mandatory guideline to assist employers and employees in complying with the requirements of this section, as well as to provide other helpful information. Nothing in the Appendix adds to or detracts from any of the requirements of this section.

**APPENDIX A TO §1910.147  
TYPICAL MINIMAL LOCKOUT PROCEDURE**

General

The following simple lockout procedure is provided to assist employers in developing their procedures so they meet the requirements of this standard. When the energy isolating devices are not lockable, tagout may be used, provided the employer complies with the provisions of the standard which require additional training and more rigorous periodic inspections. When tagout is used and the energy isolating devices are lockable, the employer must provide full employee protection (see paragraph (c)(3)) and additional training and more rigorous periodic inspections are required. For more complex systems, more comprehensive procedures may need to be developed, documented and utilized.

Lockout Procedure

Lockout procedure for \_\_\_\_\_ (Name of Company for single procedure or identification of equipment if multiple procedures are used)

Purpose

This procedure establishes the minimum requirements for the lockout of energy isolating devices whenever maintenance or servicing is done on machines or equipment. It shall be used to ensure that the machine or equipment is stopped, isolated from all potentially hazardous energy sources and locked out before employees perform any servicing or maintenance where the unexpected energization or start-up of the machine or equipment or release of stored energy could cause injury.

Compliance With This Program

All employees are required to comply with the restrictions and limitations imposed upon them during the use of lockout. The authorized employees are required to perform the lockout in accordance with this procedure. All employees, upon observing a machine or piece of equipment which is locked out to perform servicing or maintenance shall not attempt to start, energize or use that machine or equipment.

Type of compliance enforcement to be taken for violation of the above.

Sequence of Lockout

- (1) Notify all affected employees that servicing or maintenance is required on a machine or equipment and that the machine or equipment must be shut down and locked out to perform the servicing or maintenance.  
 \_\_\_\_\_ Name(s)/Job Title(s) of affected employees and how to notify.
- (2) The authorized employee shall refer to the company procedure to identify the type and magnitude of the energy that the machine or equipment utilizes, shall understand the hazards of the energy, and shall know the methods to control the energy.  
 \_\_\_\_\_ Type(s) and magnitude(s) of energy, its hazards and the methods to control the energy.
- (3) If the machine or equipment is operating, shut it down by the normal stopping procedure (depress stop button, open switch, close valve, etc.).  
 \_\_\_\_\_ Type(s) and location(s) of machine or equipment operating controls.
- (4) De-activate the energy isolating device(s) so that the machine or equipment is isolated from the energy source(s).  
 \_\_\_\_\_ Type(s) and location(s) of energy isolating devices.
- (5) Lock out the energy isolating device(s) with assigned individual lock(s).
- (6) Stored or residual energy (such as that in capacitors, springs, elevated machine members, rotating flywheels, hydraulic systems, and air, gas, steam, or water pressure, etc.) must be dissipated or restrained by methods such as grounding, repositioning, blocking, bleeding down, etc.  
 \_\_\_\_\_ Type(s) of stored energy - methods to dissipate or restrain.
- (7) Ensure that the equipment is disconnected from the energy source(s) by first checking that no personnel are exposed, then verify the isolation of the equipment by operating the push button or other normal operating control(s) or by testing to make certain the equipment will not operate.  
 CAUTION: Return operating control(s) to neutral or "off" position after verifying the isolation of the equipment.  
 \_\_\_\_\_ Method of verifying the isolation of the equipment.
- (8) The machine or equipment is now locked out.

Restoring Equipment to Service. When the servicing or maintenance is completed and the machine or equipment is ready to return to normal operating condition, the following steps shall be taken.

- (1) Check the machine or equipment and the immediate area around the machine or equipment to ensure that nonessential items have been removed and that the machine or equipment components are operationally intact.
- (2) Check the work area to ensure that all employees have been safely positioned or removed from the area.
- (3) Verify that the controls are in neutral.

- (4) Remove the lockout devices and reenergize the machine or equipment.

**Note:** The removal of some forms of blocking may require reenergization of the machine before safe removal.

- (5) Notify affected employees that the servicing or maintenance is completed and the machine or equipment is ready for use.